

## Warranty, Service & Repair

To register your product with the manufacturer, go to the Flowline website for on-line registration. The website address is as follows:

*www.flowline.com.*

On-line Warranty Registration can be found under Contact Us in the Navigation Bar along the side of the home page.

If for some reason your product must be returned for factory service, contact Flowline Inc. at (562)598-3015 to receive a Material Return Authorization number (MRA), providing the following information:

1. Part Number, Serial Number
2. Name and telephone number of someone who can answer technical questions related to the product and its application.
3. Return Shipping Address
4. Brief Description of the Symptom
5. Brief Description of the Application

Once you have received a Material Return Authorization number, ship the product prepaid in its original packing to:

Flowline Factory Service  
MRA \_\_\_\_\_  
10500 Humbolt Street  
Los Alamitos, CA 90720

To avoid delays in processing your repair, write the MRA on the shipping label. Please include the information about the malfunction with your product. This information enables our service technicians to process your repair order as quickly as possible.

# FLOWLINE®

## Remote Relay Controller LC80 and LC82 Series Owner's Manual



Version 4.2A

© 2005 FLOWLINE Inc.

All rights reserved.

Manual # LC900009

05/05

## WARRANTY

Flowline warrants to the original purchaser of its products that such products will be free from defects in material and workmanship under normal use and service for a period which is equal to the shorter of one year from the date of purchase of such products or two years from the date of manufacture of such products.

This warranty covers only those components of the products which are non-moving and not subject to normal wear. Moreover, products which are modified or altered, and electrical cables which are cut to length during installation are not covered by this warranty.

Flowline's obligation under this warranty is solely and exclusively limited to the repair or replacement, at Flowline's option, of the products (or components thereof) which Flowline's examination proves to its satisfaction to be defective. FLOWLINE SHALL HAVE NO OBLIGATION FOR CONSEQUENTIAL DAMAGES TO PERSONAL OR REAL PROPERTY, OR FOR INJURY TO ANY PERSON.

This warranty does not apply to products which have been subject to electrical or chemical damage due to improper use, accident, negligence, abuse or misuse. Abuse shall be assumed when indicated by electrical damage to relays, reed switches or other components. The warranty does not apply to products which are damaged during shipment back to Flowline's factory or designated service center or are returned without the original casing on the products. Moreover, this warranty becomes immediately null and void if anyone other than service personnel authorized by Flowline attempts to repair the defective products.

Products which are thought to be defective must be shipped prepaid and insured to Flowline's factory or a designated service center (the identity and address of which will be provided upon request) within 30 days of the discovery of the defect. Such defective products must be accompanied by proof of the date of purchase.

Flowline further reserves the right to unilaterally waive this warranty and to dispose of any product returned to Flowline where:

- a. There is evidence of a potentially hazardous material present with product.
- b. The product has remained unclaimed at Flowline for longer than 30 days after dutifully requesting disposition of the product.

THERE ARE NO WARRANTIES WHICH EXTEND BEYOND THE DESCRIPTION ON THE FACE OF THIS WARRANTY. This warranty and the obligations and liabilities of Flowline under it are exclusive and instead of, and the original purchaser hereby waives, all other remedies, warranties, guarantees or liabilities, express or implied. EXCLUDED FROM THIS WARRANTY IS THE IMPLIED WARRANTY OF FITNESS OF THE PRODUCTS FOR A PARTICULAR PURPOSE OR USE AND THE IMPLIED WARRANTY OF MERCHANTABILITY OF THE PRODUCTS.

This warranty may not be extended, altered or varied except by a written instrument signed by a duly-authorized officer of Flowline, Inc.

# SPECIFICATIONS

## Step One

- Supply voltage: 120/240 VAC @ 50-60 Hz.
- Consumption: 5 watts max.
- Sensor inputs: LC80: (1) four-wire flow switch  
LC82: (2) four-wire flow switches
- Sensor supply: 13.5 VDC @ 100 mA
- Contact type: LC80: (1) SPDT relay  
LC82: (2) SPDT relays
- Contact rating: 250 VAC @ 10A
- Contact latch: LC80: N/a  
LC82: Select ON/OFF
- Contact delay: 0-60 seconds
- LED indication: Sensor, power and relay status
- Electronics temp.: F: -40° to 158°  
C: -40° to 70°
- Enclosure type: 35 mm DIN rail
- Encl. material: PP, UL94VO
- Classification: General purpose
- Certificate: CSA: LR 79326
- CE compliance: EN 50082-2 immunity  
EN 55011 emission  
EN 61010-1 safety

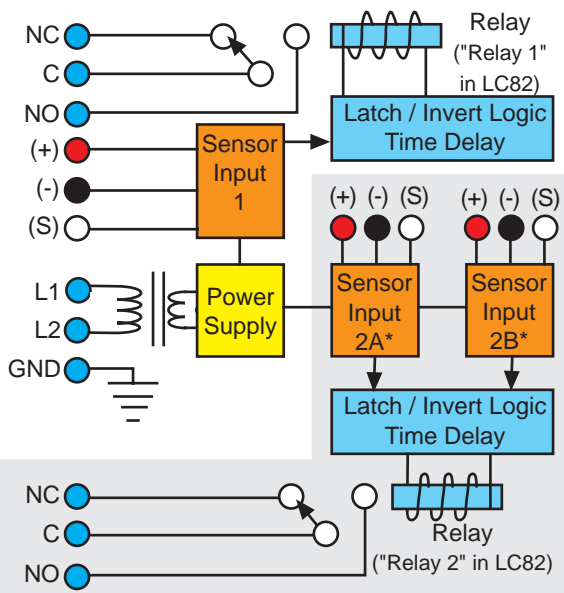

### Remote Relay Controller

**LC8 - 1001**  
Configuration  
0 - (1) SPDT Relay  
2 - (2) SPDT Relays

## Dimensions:

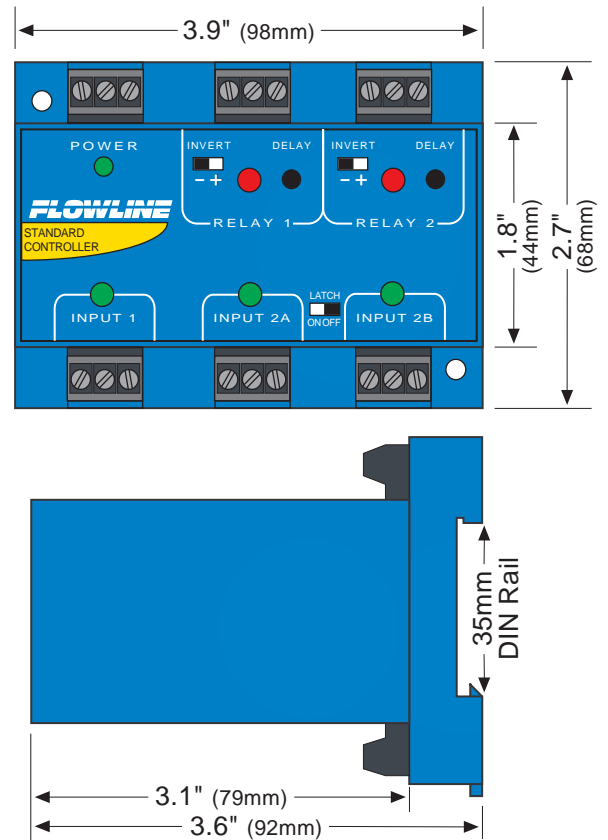

### LC82 Faceplate:

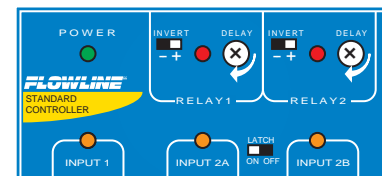

### LC80 Faceplate:

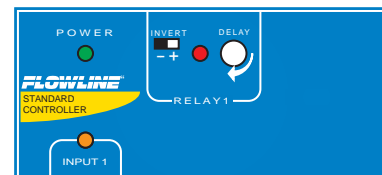

## SAFETY PRECAUTIONS

### Step Two

#### **About This Manual:**

PLEASE READ THE ENTIRE MANUAL PRIOR TO INSTALLING OR USING THIS PRODUCT. This manual includes information on two different models of Remote Relay Controllers for Flow applications from Flowline: LC80-1001 and LC82-1001. Many aspects of installation and use are similar between the two models.

#### **User's Responsibility for Safety:**

Flowline manufactures several models of controller, with different mounting and switching configurations. It is the user's responsibility to select a controller model that is appropriate for the application, install it properly, perform tests of the installed system, and maintain all components.

#### **Electrical Shock Hazard:**

It is possible to contact components on the controller that carry high voltage, causing serious injury or death. All power to the controller and the relay circuit(s) it controls should be turned OFF prior to working on the controller. If it is necessary to make adjustments during powered operation, use extreme caution and use only insulated tools. Making adjustments to powered controllers is not recommended. Wiring should be performed by qualified personnel in accordance with all applicable national, state and local electrical codes.

#### **Flammable or Explosive Applications:**

*LC80 series remote mount controllers should not be used with explosive or flammable liquids, which require an intrinsically safe rating such as the Flowline LC90 series. If you are unsure of the suitability of a controller for your installation, consult your Flowline representative for further information.*

#### **Install In a Dry Location:**

The controller housing is not designed to be immersed. It should be mounted in such a way that it does not come into contact with liquid. Its case is made out of PP (polypropylene). Refer to an industry reference to ensure that compounds that may splash onto the controller housing will not damage it. Such damage is not covered by the warranty.

#### **Relay Contact Rating:**

The relay is rated for a 10 amp resistive load. Many loads (such as a motor during start-up or incandescent lights) are reactive and have an inrush current characteristic that may be 10 to 20 times their steady-state load rating. The use of a contact protection circuit may be necessary for your installation if the 10 amp rating does not provide an ample margin for such inrush currents.

## INTRODUCTION

### Step Three

#### **Make a Fail-Safe System:**

Design a fail-safe system that accommodates the possibility of relay or power failure. If power is cut off to the controller, it will de-energize the relay. Make sure that the de-energized state of the relay is the safe state in your process. For example, if controller power is lost, a pump will turn off if it is connected to the Normally Open side of the relay.

While the internal relay is reliable, over the course of time relay failure is possible in two modes: under a heavy load the contacts may be "welded" or stuck into the energized position, or corrosion may build up on a contact so that it will not complete the circuit when it should. In critical applications, redundant backup systems and alarms must be used in addition to the primary system. Such backup systems should use different sensor technologies where possible.

While this manual offers some examples and suggestions to help explain the operation of Flowline products, such examples are for information only and are not intended as a complete guide to installing any specific system.

# GUIDE TO CONTROLS

## Step Four

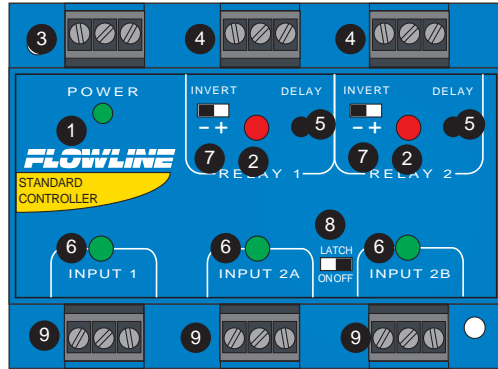

- 1. Power indicator:** This green LED lights when AC power is ON.
- 2. Relay indicator:** This red LED will light whenever the controller energizes the relay, in response to the proper condition at the switch input and after the time delay.
- 3. AC Power terminals:** Connection of 120 VAC power to the controller. The setting may be changed to 240 VAC if desired. This requires changing internal jumpers; this is covered in the Installation section of the manual. Polarity (neutral and hot) does not matter.
- 4. Relay terminals (NC, C, NO):** Connect the device you wish to control (pump, alarm etc.) to these terminals: supply to the Common (COM) terminal, and the device to the Normally Open (NO) or Normally Closed (NC) terminal as required. The switched device should be a noninductive load of not more than 10 amps; for reactive loads the current must be derated or protection circuits used. When the red LED is ON and the relay is in the energized state, the NO terminal will be closed and the NC terminal will be open.
- 5. Time delay:** Use potentiometer to set delay from 0.15 to 60 seconds. Delay occurs during switch make and switch break.
- 6. Input indicators:** Use these LEDs for indicating Flow or No-Flow status of switch. For NC wiring, an Amber LED indicates No-Flow and no LED indicates Flow. For NO wiring, an Amber LED indicates Flow and no LED indicates No-Flow.
- 7. Invert switch:** This switch reverses the logic of the relay control in response to the switch: conditions that used to energize the relay will now de-energize the relay and vice versa.
- 8. Latch switch (LC82):** This switch determines how the relay will be energized in response to the two sensor inputs. When LATCH is OFF, the relay responds to switch Input 2A only; when LATCH is ON, the relay will energize or de-energize only when both switches (2A and 2B) are in the same condition (Flow or No-Flow). The relay will remain latched until both switches change conditions.
- 9. Input terminals:** Connect the switch wires to these terminals: Note the polarity: (+) is a 24 VDC, 50 mA power supply (connected to the red wire of a Flowline flow switch), and (-) is the common ground path from the switch (connected to the black wire). Also, the (S) is a 14 VDC, 25 mA supply (connected to the white wire). If polarity between the red and black wires is reversed, the switch will change from NC to NO.

# INSTALLATION

## Step Five

### Panel DIN Rail Mounting:

The controller may be mounted by either a back panel using two screws through mounting holes located at the corners of the controller or by snapping the controller on 35 mm DIN Rail.

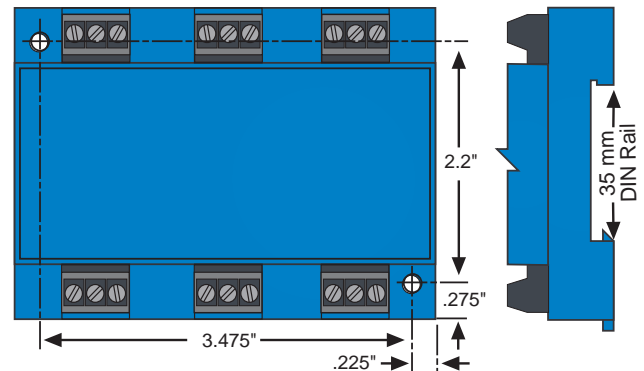

**Note:** Always install the controller in a location where it does not come into contact with liquid.

### Connecting N-channel Switches to Input Terminals:

Please note a difference between Flowline flow switches (N-channel, P-channel and Relay). Use only the N-Channel or Relay switches with the LC80 series of controller. Wire the Red wire to the (+) terminal and the Black wire to the (-) terminal. Wire the White wire to the (S). See the illustration below to indicate wiring for your switch. Reversing Red and Black wire will change switch from NC to NO. Note: connect the Shield wire on the Flow switch to the GND terminal if required.

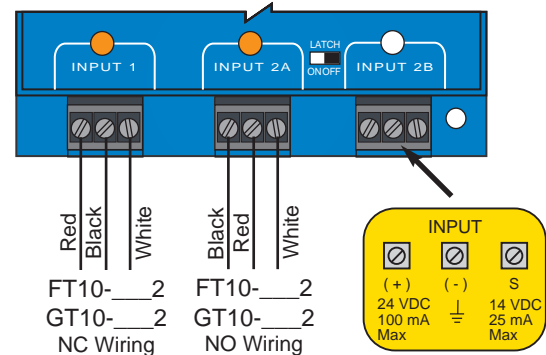

# INSTALLATION

## Step Six

### Connecting Relay Switches to Input Terminals:

Please note a difference between Flowline flow switches (N-channel, P-channel and Relay). Use only the N-Channel or Relay switches with the LC80 series of controller. Wire the Red wire to the (+) terminal and the Black wire to the (-) terminal. Wire the White wire to the (S). Jumper the Green wire to the (-) terminal. See the illustration below to indicate wiring for your switch. Reversing Red and Black wire will change switch from NO to NC. Note: connect the Shield wire on the Flow switch to the GND terminal if required.

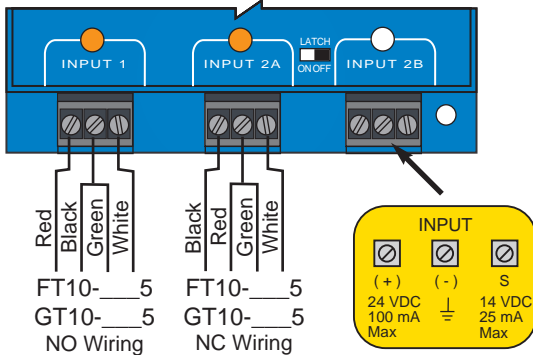

### LED Indication:

Use LED's located above the input terminals to indicate whether the switch is in a Flow or No-Flow state. With the flow switch wired NC, the Amber LED indicates *No-Flow* and no LED indicates *flow*. Wiring the switch NO (reversing the Red and Black wires), the Amber LED indicates *Flow* and no LED indicates *No-Flow*.

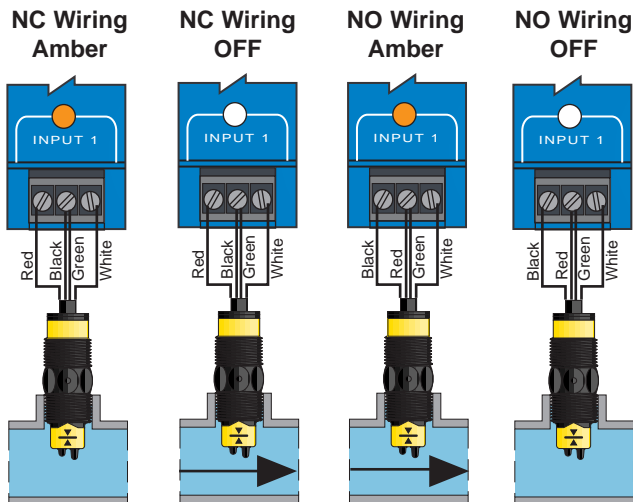

# INSTALLATION

## Step Seven

### VAC Power Input Wiring

Observe the POWER SUPPLY label on the LC80 series. The label identifies the power requirement (120 or 240 VAC) and the terminal wiring. **Note:** Polarity does not matter with the AC input terminal.

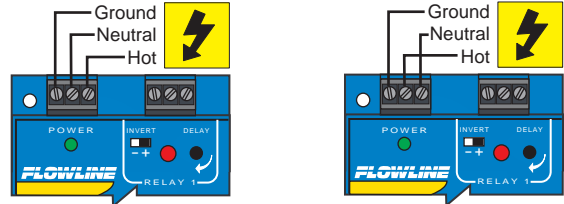
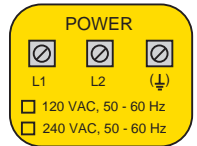

### Relay Input Wiring

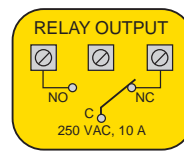

The relay is a single pole, double throw type rated at 250 Volts AC, 10 Amps. The two terminal NO and NC (normally open and normally closed) will be used in different applications. Remember that the "normal" state is when the relay coil is de-energized and the Red relay LED is Off / de-energized.

### Changing from 120 to 240 VAC

1. Remove the back panel of the controller and gently slide the printed circuit board from the housing. Use caution when removing the PCB.
2. Located jumpers JW1, JW2 and JW3 on the PCB.
3. To change to 240 VAC, remove jumpers from JW1 and JW2 and place a single jumper across JW3. To change to 120 VAC, remove jumper JW3 and place jumpers across JW1 and JW2.
4. Gently return PCB into housing and replace back panel.

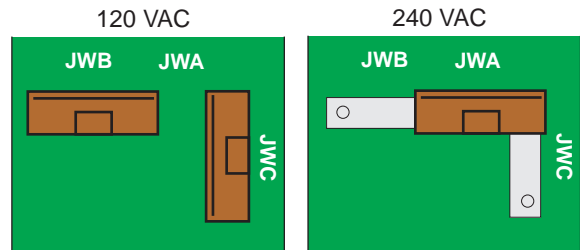

## EXAMPLES

### Step Eight

**Low Flow Alarm:** The goal is to indicate when the flow rate falls below a certain point. If it does, an alarm is supposed to sound, alerting the operator of a low flow condition.

If power is accidentally cut to the controller, the sensor's ability to notify the operator of a low flow condition could be lost. The system must alert the operator not only to low flow, but to controller power loss. To do this, connect the hot lead of the alarm to the NC side of the relay terminal of the controller. If power is lost, the relay will be de-energized, and the alarm will sound (if there is still power to the alarm circuit itself). The alarm circuit should have a non-interruptible power supply or some other indicator or backup alarm to warn of a power failure in the alarm circuit.

In this application, the normal status is when the sensor is in the flow condition, and the relay will be energized holding the alarm circuit open. If the switch is wired NC, the input LED will be off and the relay LED will be on. So for this application, Invert should be set to the On position. If the switch is wired NO, the input LED and the relay LED will be on simultaneously. So for this application, Invert should be set to the Off (-) position.

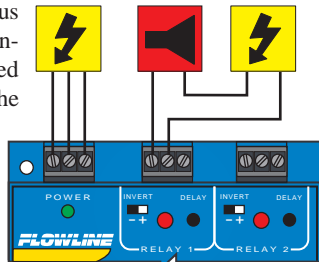

**Invert ON (+) setting**

## TROUBLESHOOTING

### Step Nine

**Controller Logic:** For all controllers, please use the following guide to understand the operation of the Flowline LC80/LC82 controllers.

1. Make sure the Green power LED is On when power is supplied to the controller.
2. For NC switch wiring, the input LED's on the controllers will be Amber when the switch reads no-flow and Off when the switch reads flow.
3. The input LED will always respond to its corresponding relay LED. With invert Off (-), the relay LED will be On when the input LED is On and Off when the input LED is Off. With invert On (+), the relay LED will be Off when the input LED is On and On when the input LED is Off.
4. The relay may be wired either NO or NC. The normal state of the relay is when its LED is Off. With the LED On, the relay is in the energized mode and all terminal connections are reversed.
5. LC82 model only, Latch ON operation: When both input LED's are ON, the relay will be energized (red LED On). After that, if one switch input turns Off, the relay will remain energized. Only when both switch LED's are Off will the controller de-energize the relay. The relay will not energize again until both switch LED's are ON. Reversing Invert switch will reverse logic. See the Logic Chart below for further explanation.

**Set Points:** If the preset factory calibration is not adequate for your application, follow the calibration steps listed below. *Note: the switch's internal LED will be on when the switch detects no-flow and will off when the switch detects flow.*

1. Install the fitting and flow switch as described in the Installation section of this manual. Turn the flow switch and controller power on and adjust the flow rate to the application setting. If the medium to be sensed is likely to be subject to high temperature variations, the flow switch should be set at the highest normal temperature likely to be encountered.
2. Locate the potentiometer knob at the top of the flow switch. The red LED is visible through the potentiometer. (If the LED is on, slowly adjust the potentiometer counterclockwise, with a small flat head screwdriver until the LED turns off.) The adjustment is a single turn 270° potentiometer. The initial response time of the flow switch after adjustment is 1 to 10 seconds. Adjust the potentiometer in slow increments and wait for the response.

If the LED is off, slowly adjust the potentiometer clockwise until the light turns on. Then turn the potentiometer counterclockwise to bring the LED off at a reliable setting. Remember, adjust the potentiometer in slow increments and wait for the response.

3. Verify that the new calibration is correct by lowering the system flow rate below the set point and check to see that the red LED turns on. Then increase the flow rate above the set point and verify that the red LED turns off accordingly.

**Liquid Switch**  
FT10-\_\_ 5 Series

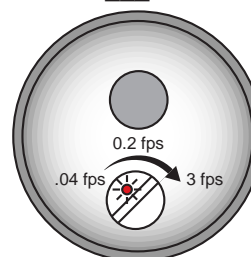

**Gas Switch**  
GT10-\_\_ 5 Series

