

## **Thermo-Flo™**

### **Thermal Dispersion Flow Switch**

#### **FT10 & GT10 Series Manual**



**Flowline Inc.**  
10500 Humbolt Street  
Los Alamitos, CA 90720  
Tel: (562) 598-3015  
Fax: (562) 431-8507  
[www.flowline.com](http://www.flowline.com)

Offered in liquid and gas sensor types, the general purpose flow switch provides reliable low or no-flow detection of relatively clean, non-coating media with one 1A relay output. Liquid examples include water and acetic acid. Available in Polypropylene-Ryton® or PVDF, the short flow sensor is used in pipe or ducting from ½” to 1-1/2”, and the long flow sensor is used in 2” and up. The flow switch set point may be adjusted from 0.04 to 3 fps in liquids or 1 to 90 fps in gases as a low-flow alarm. The flow sensor is best applied in applications with relatively constant temperatures.

**New Features**

- Rugged Polypropylene-Ryton® or PVDF sensor for corrosive liquids and gasses.
- Adjustable set point with LED for flow or no-flow status indication.
- 60VA relay selectable NO or NC via power supply wiring polarity
- Solid State sensor is not damaged by over-ranging flow velocities.

**Table of Contents**

Specifications: ..... 3  
     Make a Fail-Safe system: ..... 3  
 Dimensions:..... 4  
     Configurations:..... 4  
 Safety Precautions: ..... 5  
 Introductions:..... 6  
     Technology:..... 6  
 Installation: ..... 7  
 Wiring:..... 8  
     Wiring to a Flowline Controller:..... 8  
     Wiring the Relay output:..... 9  
     Wiring as a P-Channel or N-Channel Output: ..... 10  
 Calibration:..... 11  
     Set Point:..... 11  
 Maintenance: ..... 12  
     Cleaning Procedure:..... 12  
     Testing the Sensor (FT10 Series Only): ..... 12  
     Testing the Sensor (GT10 Series Only):..... 13  
 Warranty: ..... 14

Set point range: FT10: .04 to 3 fps (.012 to .91 mps)  
 GT10: 1 to .90 fps (.3 to 27 mps)

Factory set point: FT10: .2 fps (.06 mps)  
 GT10: 10 fps (3 mps)

Repeatability: ±.5% of set point @ fixed temp.

Response time: 1-10 seconds

Set point adjust.: Potentiometer

LED indication: Flow Status

Viscosity range: 1-200 centipoise (FT10 only)

Supply Voltage: 14-36 VDC

Consumption: 70 mA maximum

Contact type: (1) SPST relay

Contact rating: 60 VA, 1A max

Contact output: Selectable NO/NC

Process temp.: F:32° to 140°  
 C: 0° to 60°

Electronics temp. F: -40° to 140°  
 C: -40° to 60°

Pressure: 150 psi (10 bar) @ 25°C., derated @ 1.667  
 psi (.113 bar) per °C. Above 25° C.

Sensor rating: NEMA 4X (IP65)

Sensor Material: 1\_\_5: PP-Ryton®  
 5\_\_5: PVDF

Cable jacket mat.: 1\_\_5: PP  
 5\_\_5: FEP

Cable type: 4-conductor, #22 AWG (shielded)

Cable length: Standard: 10' (3m)  
 Special order: 25' (7.6m) or 50' (15.2m)

Process mount: 3/4" NPT (3/4" G/R)

Mount. Gasket: Viton® (G version only)

Classification: General purpose

CE compliance: EN 61326 EMC  
 EN 61010-1 safety

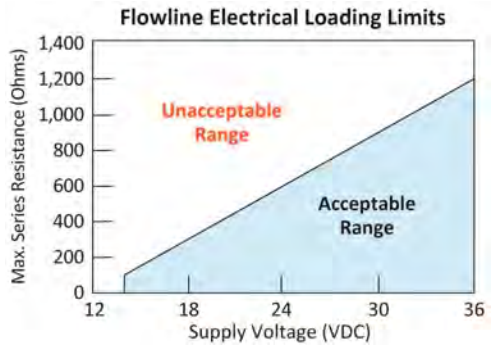
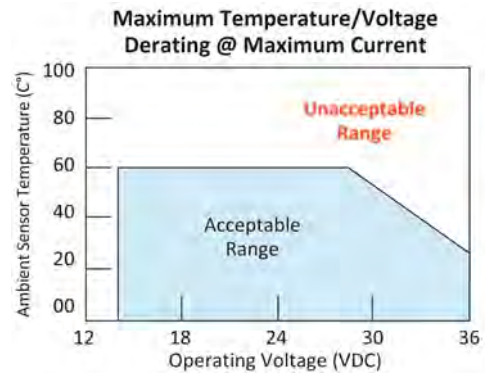
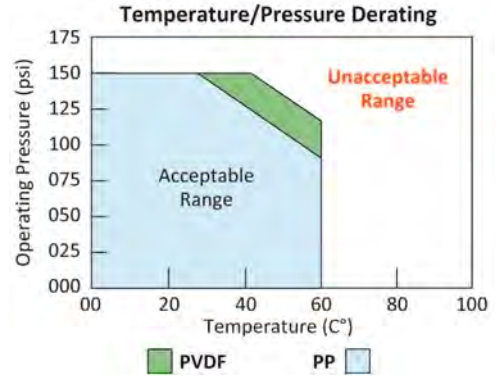

**⚠ Make a Fail-Safe System:** Design a fail-safe system that accommodates the possibility of switch and/or power failure. FLOWLINE recommends the use of redundant backup systems and alarms in addition to the primary system. Adding a redundant alarm switch to the system is a cost effective means to prevent costly run-dry issues.

Long Sensor (FT10 - \_ 4 \_\_ or GT10 - \_ 4 \_\_)

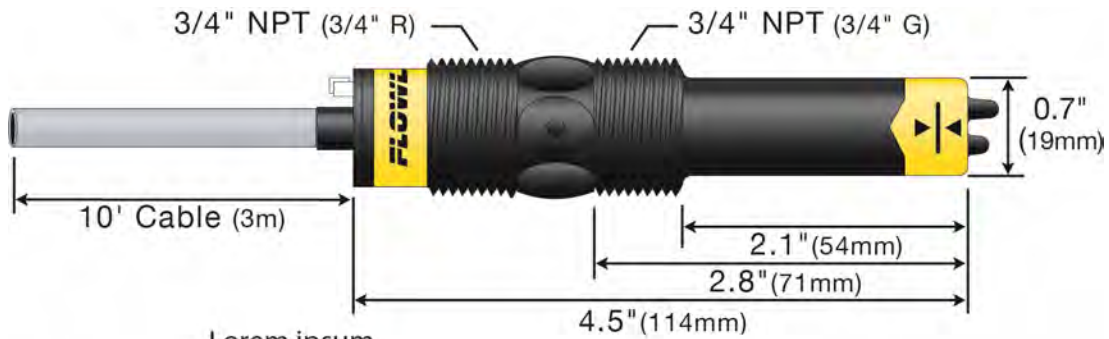

Lorem ipsum

Short Sensor (FT10 - \_ 3 \_\_ or GT10 - \_ 3 \_\_)



Configurations (Liquid Flow Switches):

Part Number	Length	Material (body)	Material (cable)	Thread (inside x outside)
FT10-1305	Short (3")	PP-Ryton®	Polypropylene	3/4" NPT x 3/4" NPT
FT10-1325	Short (3")	PP-Ryton®	Polypropylene	3/4" R x 3/4" R
FT10-1405	Long (4.5")	PP-Ryton®	Polypropylene	3/4" NPT x 3/4" NPT
FT10-1425	Long (4.5")	PP-Ryton®	Polypropylene	3/4" R x 3/4" G
FT10-5305	Short (3")	PVDF	FEP	3/4" NPT x 3/4" NPT
FT10-5325	Short (3")	PVDF	FEP	3/4" R x 3/4" R
FT10-5405	Long (4.5")	PVDF	FEP	3/4" NPT x 3/4" NPT
FT10-5425	Long (4.5")	PVDF	FEP	3/4" R x 3/4" G

Configurations (Gas Flow Switches):

Part Number	Length	Material (body)	Material (cable)	Thread (inside x outside)
GT10-1305	Short (3")	PP-Ryton®	Polypropylene	3/4" NPT x 3/4" NPT
GT10-1325	Short (3")	PP-Ryton®	Polypropylene	3/4" R x 3/4" R
GT10-1405	Long (4.5")	PP-Ryton®	Polypropylene	3/4" NPT x 3/4" NPT
GT10-1425	Long (4.5")	PP-Ryton®	Polypropylene	3/4" R x 3/4" G
GT10-5305	Short (3")	PVDF	FEP	3/4" NPT x 3/4" NPT
GT10-5325	Short (3")	PVDF	FEP	3/4" R x 3/4" R
GT10-5405	Long (4.5")	PVDF	FEP	3/4" NPT x 3/4" NPT
GT10-5425	Long (4.5")	PVDF	FEP	3/4" R x 3/4" G

**⚠ About this Manual:** PLEASE READ THE ENTIRE MANUAL PRIOR TO INSTALLING OR USING THIS PRODUCT. This manual includes information on all models of Flowline Thermo-Flo™ Flow Switches: FT10 and GT10 series. Please refer to the part number located on the switch label to verify the exact model which you have purchased.

**⚠ User's Responsibility for safety:** Flowline manufactures a wide range of flow switches and technologies, while each of these sensors is designed to operate in a wide variety of applications, it is the user's responsibility to select a sensor model that is appropriate for the application, install it properly, perform tests of the installed system, and maintain all components. The failure to do so could result in property damage or serious injury.

**⚠ Proper Installation and Handling:** Because this is an eclectically operated device, only properly trained staff should install and/or repair this product. Use a proper sealant with all installations. **Note:** *Always install the 3/4" Viton gasket with all versions of Thermo-Flo™ with metric threads. The G threaded version will not seal unless the gasket is properly installed.* Never over tighten the sensor within the fitting, beyond a maximum of 80 inch-pounds torque. Always check for leaks prior to system start-up.

**⚠ Material Compatibility:** The FT10 and GT10 series sensors are available in two different wetted materials. Models FT10-1\_\_5 and GT10-1\_\_5 are made of Polypropylene (PP) with Ryton® tips. Models FT10-5\_\_5 and GT10-5\_\_5 are made of Polyvinylidene Fluoride (PVDF). Make sure that the model you have selected is compatible with the application liquid. To determine the chemical compatibility between the sensor and its application liquids, refer to an industry reference such as the Compass Corrosion Guide (available from Compass Publications).

**⚠ Wiring and Electrical:** The supply voltage used to power the sensor should never exceed a maximum of 36 volts DC. Electrical wiring of the sensor should be performed in accordance with all applicable national, state, and local codes.

**⚠ Flammable, Explosive and Hazardous Applications: DO NOT USE THE FT10 OR GT10 SERIES GENERAL PURPOSE FLOW SWITCHES IN HAZAROUS LOCATIONS.**

**⚠ Warning ⚠**

- ⚠ *The rating for the relay is 60 VA, 1Amp max.*
- ⚠ *Flowline's Thermo-Flo™ flow switches are not recommendable for use with electrically charged application liquids. For most reliable operation, the liquid being measured may need to be electrically grounded.*
- ⚠ *The sensing tip of the sensor must always be submersed in the liquid and never exposed to air.*
- ⚠ *The liquid temperature must remain constant and not change throughout the process.*

**Technology:** The thermal dispersion flow switches measure liquid or gas temperature to determine changes in flow velocity. As fluid flows across the sensing tips, the temperature is reduced proportionately as a function of the flow rate. When a temperature or velocity shift reaches the user defined set point, the switch changes state indicating the appropriate flow condition (flow or no-flow).

FLOWLINE's sophisticated electronics convert the temperature shift into a signal which indicates whether a flow or no-flow condition occurs. Depending on how the sensor is wired, this signal may be wired for normally open or normally closed circuits.

FLOWLINE's Thermo-Flo™ flow switches have no moving parts to clog or foul, making them suitable for a verity of applications, including non-coating and non-scaling liquids. The FT10 series directly measure mass flow and can operate over board range of liquids from 0.4 to 1.2 specific gravity and 1 to 300 cp.

**Initializing Sequence for FT10 series:** When the flow switch is powered up while submersed, the FT10 will immediately indicate flow before switching to its correct state. A time delay may be used to eliminate the initialization sequence. Flowline's thermal dispersion relay controllers feature a 0 to 60 second time delay for your convenience.

**Set Points:** The FT10 liquid flow switch set point is factory calibrated to 0.2 fps and the GT10 gas flow switch are set to 10 fps. To convert feet/sec to GPM, please refer to the chart below.

**FT10**  
Flow Rate vs. Velocity  
(gpm vs. fps)

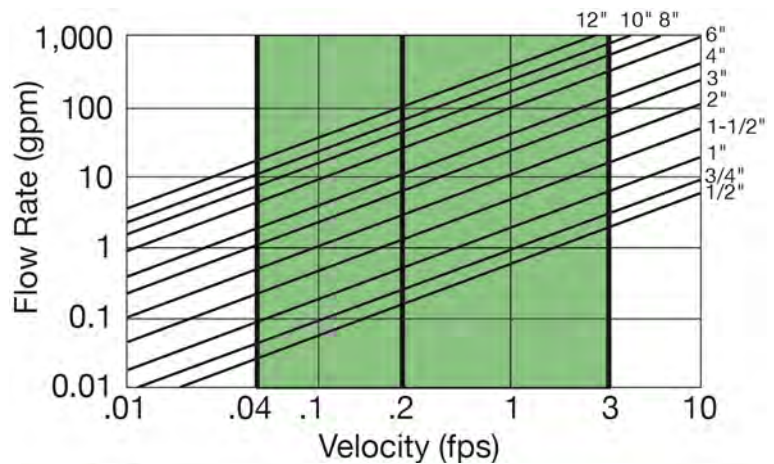

**GT10**  
Flow Rate vs. Velocity  
(cfm vs. fps)

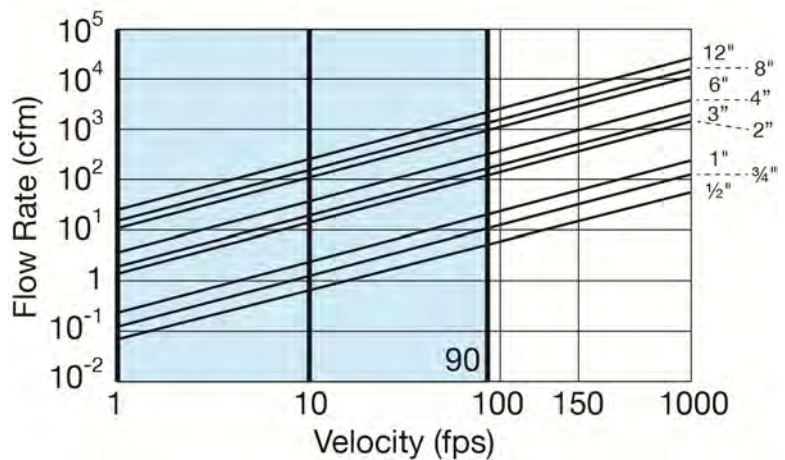

The FT10 series flow switch must always be in contact with the liquid being measured. The GT10 series flow switch must never be submersed in liquid. Both flow switches feature a 3/4" NPT threads which will allow it to be used with various types of fittings. Be sure to check the insertion depth of the flow switch in the fitting after it is installed. See the diagram to the right for the recommended insertion depth.

- The two tips of the sensor are to be perpendicular to the flow (as seen to the right). Never mount the tips with one in front of the other.

When using any type of fitting, the orientation as well as the insertion depth of the flow switch in the pipe is critical. See the diagram to the right for the recommended orientation. Best location for installation will be along the top of the pipe.

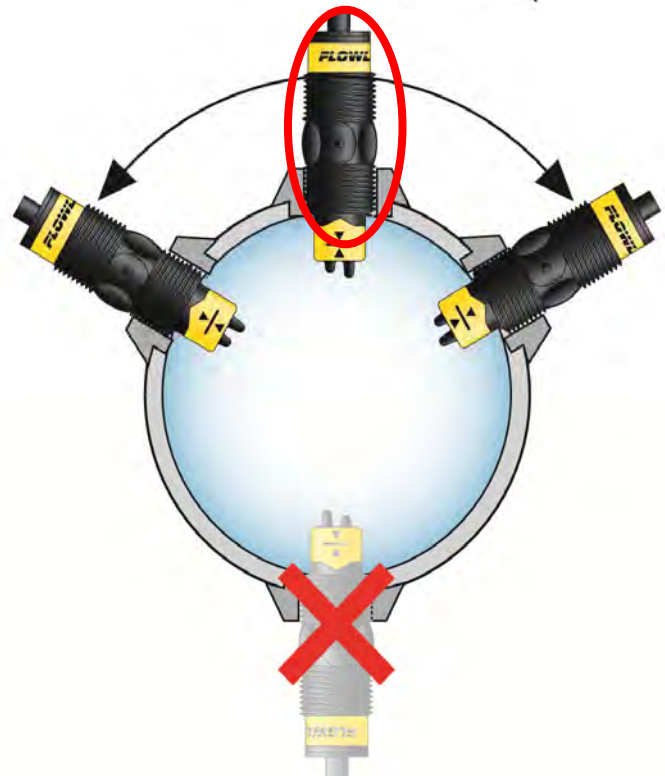
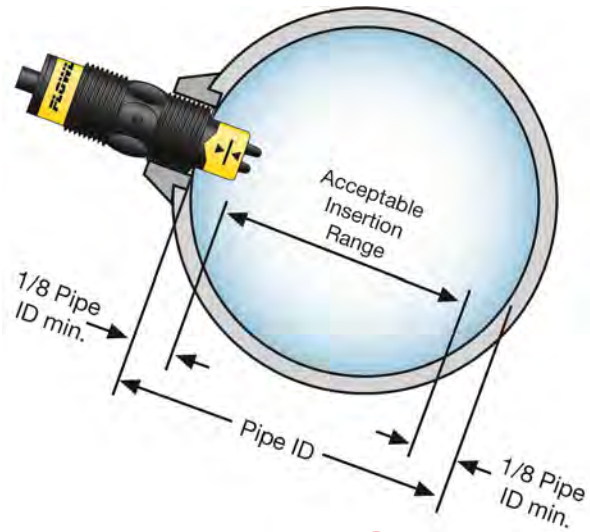

#### ⚠ Warning ⚠

- ⚠ The flow switch tips have a thin plastic wall which may be damaged if dropped or installed improperly.
- ⚠ The FT10 flow switch is designed for use in liquid. For best results, avoid installing the FT10 where bubbles are present or where the tips of the switch may be out of the liquid.
- ⚠ The GT10 flow switch is designed for use in gas applications. For best results, avoid installing the GT10 where it may be submersed in liquid.
- ⚠ Always install the Viton gasket with all versions of the FT10-\_\_2\_\_. The G threaded version will not seal unless the gasket is properly installed.
- ⚠ The two temperature probes (tips) must always be perpendicular to the flow (see the flow at the same time).

**Supply Voltage:** The supply voltage to the Thermo-Flo™ flow switch should never exceed a minimum output of 14 VDC or maximum output of 36 VDC.

**Required Cable Length:** Determine the length of the cable required between the Thermo-Flo™ flow switch and its point of termination. Allow enough slack to ensure the easy installation, removal and/or maintenance of the sensor. The cable length may be extended up to a maximum of 1000 ft, using a well-insulated, 14 to 20 gauge shield four conductor cable.

**Wire Stripping:** Using a 10 gauge wire stripper, carefully remove the outer layer of insulation from the last 1-1/4" of the sensor's cable. Unwrap and discard the exposed foil shield from around the signal wires, leaving the drain wire attached if desired. With a 20 gauge wire stripper, remove the last 1/4" of the colored insulation from the signal wires.

**Signal Output (Relay Switching):**

Allows the sensor to switch a small load on or off directly, using an internal relay rated below 60 VA. The NO/NC status is set by the polarity of the voltage feeding the red and black wires. The green wire is the common for the relay and the white wire is the NO or NC, depending on the polarity of red and black.



**Wiring to a Flowline Controller:**

**LC80 Series Controller**

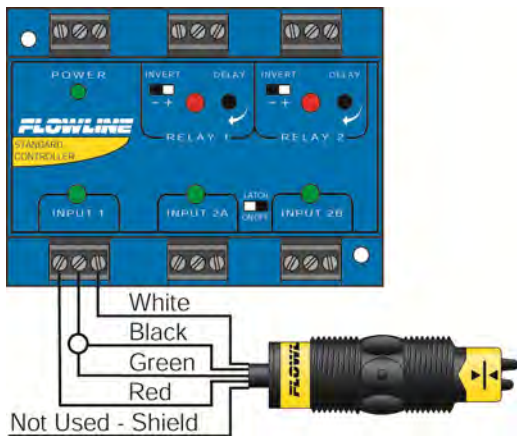

**LC30 Series Controller**

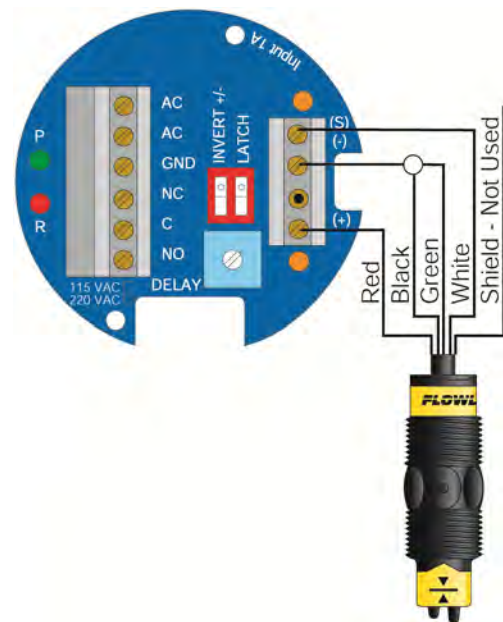



**Wiring the Relay Output:** The Thermo-Flo™ relay output can be wired as a dry contact to a VDC or VAC power source. The Thermo-Flo™ does require 14-36 VDC power to operate the sensor and switch the relay. All installations below identify a dry switch state as the normal position of the relay.

**Switching a Normally Open DC Load (Open during Flow, Closed during No-Flow):**

The Red wire connects to Positive (+) of the power supply and the Black wire connects to Negative (-). The LOAD can be attached to either the Green or White wires. Complete the circuit by connecting the Green to (+) VDC power or White to (-) VDC power (see illustration to the right).

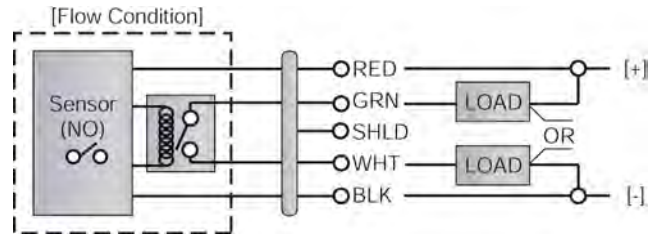

**Switching a Normally Closed DC Load (Closed during Flow, Open during No-Flow):**

The Black wire connects to positive (+) of the power supply and the Red wire connects to Negative (-). The Load can be attached to either the Green or White wires. Complete the circuit by connecting the Green to (+) VDC power or White to (-) VDC power (see illustration to the right).

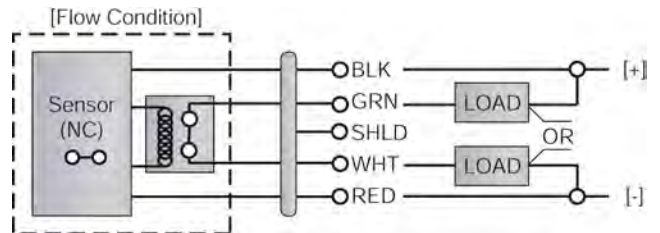

**Switching a Normally Open AC Load (Open during Flow, Closed during No-Flow):**

The Red wire connects to Positive (+) of the DC power supply and the Black wire connects to Negative (-). The LOAD can be attached to the Green wire and the Hot of the VAC power. Connect the white to the Neutral of the VAC power (see illustration to the right). Low voltage VAC is less than 36 VAC.

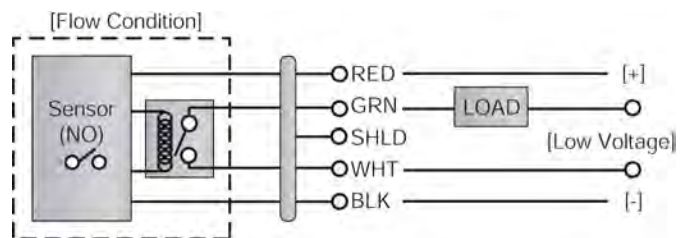

**Switching a Normally Closed AC Load (Closed during Flow, Open during No-Flow):**

The Black wire connects to Positive (+) of the DC power supply and the Red wire connects to Negative (-). The LOAD can be attached to the Green wire and the Hot of the VAC power. Connect the White to the Neutral of the VAC power (see illustration to the right). Low voltage VAC is less than 36 VAC.

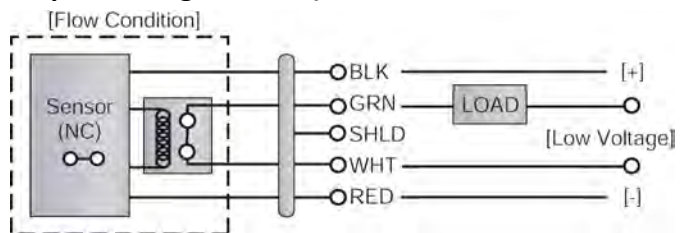

**For all Sensor Wiring diagrams above:**

Sensor Power: Red and Black Wires (36 VDC Max.)

Relay Rating: Green and White Wires (60VA, 1A Max.)

**Wiring as a P-Channel or N-Channel output:** The Thermo-Flo™ can be substituted for either a P-Channel (PNP, Sourcing) output or N-Channel (NPN, sinking) output.

**Normally Open DC Load as a P-Channel Output (Open during Flow, Closed during No-Flow):**

To wire as a NO P-Channel output follow the directions below. The Red Wire connects to Positive (+) of the power supply and the Black wire connects to Negative (-). The Green wire is jumping to the Red wire while the White wire is connected to the LOAD. Jumper the LOAD back to the Negative (-) to complete the circuit.

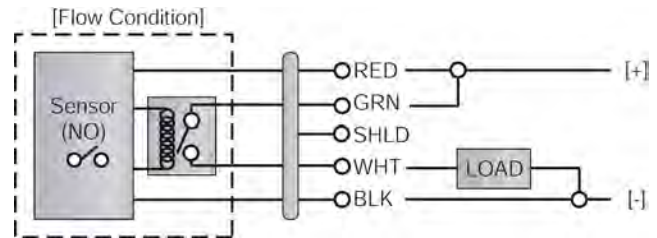

**Normally Closed DC Load as a P-Channel Output (Closed during Flow, Open during No-Flow):**

To wire as a NC P-Channel output, follow the directions below. The Black wire connects to Positive (+) of the power supply and the Red wire connects to Negative (-). The Green wire is jumping to the Black wire while the White wire is connected to the LOAD. Jumper the LOAD back to the Negative (-) to complete the circuit.

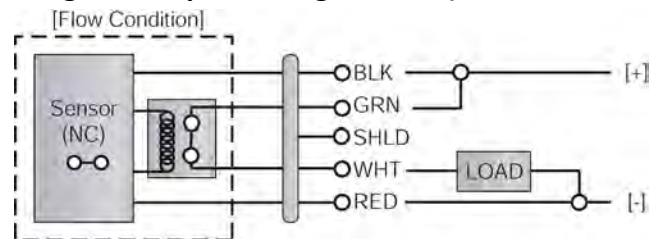

**Normally Open DC Load as a N-Channel Output (Open during Flow, Closed during No-Flow):**

To wire as a NO N-Channel output, follow the directions below. The Red wire connects to Positive (+) of the power supply and the Black wire connects to Negative (-). The white wire is jumping to the Black wire while the Green wire is connected to the LOAD. Jumper the LOAD back to the Positive (+) to complete the circuit.

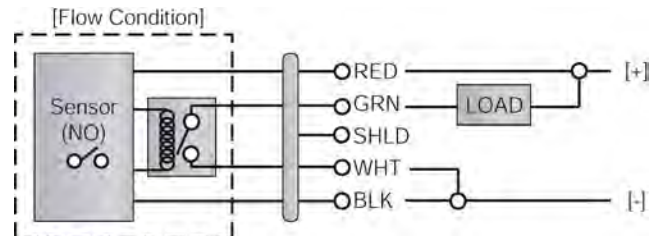

**Normally Closed DC Load as a N-Channel Output (Closed during Flow, Open during No-Flow):**

To wire as a NC N-Channel output, follow the directions below. The Black Wire connects to Positive (+) of the directions below. The Black Wire connects to Negative (-). The white wire is jumping to the Red wire while the White wire is connected to the LOAD. Jumper the LOAD back to Positive (+) to complete the circuit.

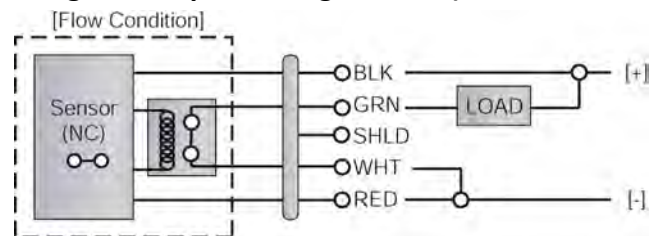

**For all Sensor Wiring diagrams above:**

Sensor Power: Red and Black Wires (36 VDC Max.)

Relay Rating: Green and White Wires (60VA, 1A Max.)

**Set Point:** If the preset factory calibration is not adequate for your application, follow the calibration steps listed below.

**Note:** The switch's internal LED will be on when the switch detects no-flow and will off when the switch detects flow, regardless of the polarity of the Red and Black wires. Reversing the Red and Black wires will reverse the polarity of the relay switch, but not the internal LED.

1. Install the fitting and flow switch as described in the Installation section of this manual. Turn the flow switch and controller power on and adjust the flow rate to the application setting. If the medium to be sensed is likely to be subject to any temperature variation, the flow switch should be set as the highest normal temperature likely to be encountered.
2. Locate the potentiometer knob at the top of the flow switch. The red LED is visible through the potentiometer. The adjustment is a single turn 270° potentiometer. The initial response time of the flow switch after adjustment is 1 to 10 seconds. Adjust the potentiometer in slow increments and wait for the response.
  - a. LED is ON - If the LED is on, slowly adjust the potentiometer counter-clockwise, with a small flat head screwdriver until the LED turn off.
  - b. LED is OFF - If the LED is off, slowly adjust the potentiometer clockwise. with a small flat head screwdriver until the light turns on.
3. Adjust the potentiometer back and forth where the LED is switching, eventually settling for where the LED is OFF (this is the low flow state for the switch).
  - a. If the flow is increased, the LED will remain OFF indicating a flow condition
  - b. If the flow is decrease, the LED will turn ON indicating a no-flow condition.
4. Verify that the new calibration is correct by lowering the system flow rate below the set point and check to see that the red LED turns on. Then increase the flow rate above the set point and verify that the red LED turns off accordingly.

**FT10 Flow Switch  
(Liquid Only)**

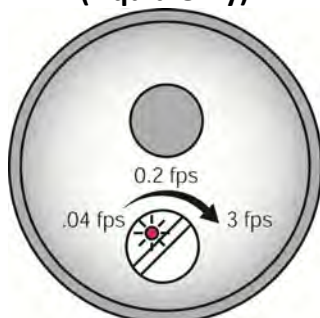

**Potentiometer  
Location**



**GT10 Flow Switch  
(Gas Only)**

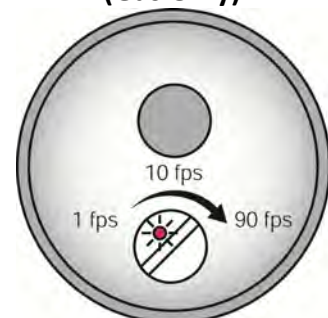

**General:** The Thermo-Flo™ switch requires no periodic maintenance except to clean off any deposits or scaling from the sensor tip as necessary. It is the responsibility of the user to determine the appropriate maintenance schedule, based on the specific characteristics of the application liquids.

**Cleaning Procedure:**

- 1. Power:** Make sure that all power to the sensor, controller and/or power supply is completely disconnected.
- 2. Sensor Removal:** *Make sure that the flow is off and the pressure is down prior to removing the Thermo-Flo™.* Carefully, remove the sensor from the installation. Replace the sensor with a 3/4" NPT plug to insure that the liquid does not leak out during this procedure. **Do not re-install the Thermo-Flo™ if the threads are damaged.**
- 3. Cleaning the sensor:** Use a soft bristle brush and mild detergent, carefully wash the Thermo-Flo™ flow switch. Do not use harsh abrasives such as steel wool or sandpaper, which might damage the surface sensor. Do not use incompatible solvents which may damage the surface sensor. Do not use incompatible solvents which may damage the sensor's PP/Ryton or PVDF plastic body.
- 4. Sensor Installation:** Follow the appropriate steps of installation as outlined in the installation section of this manual.

**Testing the Sensor (FT10 Series Only):**

- 1. Immersing the switch:** Place the switch in a cup of water. Make sure the tips are submersed in the water.
- 2. Power:** Turn on power to the switch with Red to (+) and Black to (-). You can reverse the polarity if desired.
- 3. No-Flow/Flow Test:** With the switch setting still in the cup, wait until the Red LED turns ON (no-flow condition).
  - a. Swirl the switch in the cup and wait until the Red LED turn OFF (flow condition).
  - b. Stop swirling the sensor and let it rest in the cup waiting for the Red LED to turn ON again (no-flow condition).
  - c. Repeat the above two steps.
- 4. Relay Test:** Connect a multimeter (set to read Ohms) to the White and Green Wires. Perform the above No-Flow/Flow test with the multimeter connect to observe the actuation of the relay.
  - a. With Red to (+) and Black to (-), the multimeter will read a small resistance during no-flow (closed relay) and OL during a flow condition (open relay).
  - b. Reverse Polarity [Red to (-) and Black to (+)] to see the multimeter read OL during a no-flow state (open relay) and a small resistance during a flow condition (closed relay).

The No-Flow/Flow test determines if the switch is capable of sensing the changes between no-flow and flow. The Relay test determines the ability of the relay to switch between a no-flow and flow condition. This is the basic test to determine functionality of the sensor.

**Testing the Sensor (GT10 Series Only):**

1. **Creating a No-Flow Test Point:** The purpose of this step is to create a no-flow state for the sensor to be tested against. Since this is a low flow switch, even a buildings HVAC system can create a flow that the sensor can read.
  - a. Place the switch on a table and place an empty cup over the sensing tips.
  - b. The cup will act like a shield to protect the sensor from air flow.
2. **Power:** Turn on power to the switch with Red to (+) and Black to (-). You can reverse the polarity if desired.
3. **No-Flow/Flow Test:** With the switch setting still under the cup, wait until the Red LED turns ON (no-flow condition).
  - a. Remove the cup and move the sensor in air and observe when the Red LED turn OFF (flow condition).
  - b. Place the sensor on the table and place the cup over the sensor and let it rest waiting for the Red LED to turn ON again (no-flow condition).
  - c. Repeat the above two steps.
4. **Relay Test:** Connect a multimeter (set to read Ohms) to the White and Green Wires. Perform the above No-Flow/Flow test with the multimeter connect to observe the actuation of the relay.
  - a. With Red to (+) and Black to (-), the multimeter will read a small resistance during no-flow (closed relay) and OL during a flow condition (open relay).
  - b. Reverse Polarity [Red to (-) and Black to (+)] to see the multimeter read OL during a no-flow state (open relay) and a small resistance during a flow condition (closed relay).

The No-Flow/Flow test determines if the switch is capable of sensing the changes between no-flow and flow. The Relay test determines the ability of the relay to switch between a no-flow and flow condition. This is the basic test to determine functionality of the sensor.

**Warranty**

Flowline warrants to the original purchaser of its products that such products will be free from defects in material and workmanship under normal use and service in accordance with instructions furnished by Flowline for a period of two years from the date of manufacture of such products. Flowline's obligation under this warranty is solely and exclusively limited to the repair or replacement, at Flowline's option, of the products or components, which Flowline's examination determines to its satisfaction to be defective in material or workmanship within the warranty period. Flowline must be notified pursuant to the instructions below of any claim under this warranty within thirty (30) days of any claimed lack of conformity of the product. Any product repaired under this warranty will be warranted only for the remainder of the original warranty period. Any product provided as a replacement under this warranty will be warranted for the full two years from the date of manufacture.

**Returns**

Products cannot be returned to Flowline without Flowline's prior authorization. To return a product that is thought to be defective, go to [www.flowline.com](http://www.flowline.com), and submit a customer return (MRA) request form and follow the instructions therein. All warranty and non-warranty product returns to Flowline must be shipped prepaid and insured. Flowline will not be responsible for any products lost or damaged in shipment.

**Limitations**

This warranty does not apply to products which: 1) are beyond the warranty period or are products for which the original purchaser does not follow the warranty procedures outlined above; 2) have been subjected to electrical, mechanical or chemical damage due to improper, accidental or negligent use; 3) have been modified or altered; 4) anyone other than service personnel authorized by Flowline have attempted to repair; 5) have been involved in accidents or natural disasters; or 6) are damaged during return shipment to Flowline. Flowline reserves the right to unilaterally waive this warranty and dispose of any product returned to Flowline where: 1) there is evidence of a potentially hazardous material present with the product; or 2) the product has remained unclaimed at Flowline for more than 30 days after Flowline has dutifully requested disposition. This warranty contains the sole express warranty made by Flowline in connection with its products. ALL IMPLIED WARRANTIES, INCLUDING WITHOUT LIMITATION, THE WARRANTIES OF MERCHANTABILITY AND FITNESS FOR A PARTICULAR PURPOSE, ARE EXPRESSLY DISCLAIMED. The remedies of repair or replacement as stated above are the exclusive remedies for the breach of this warranty. IN NO EVENT SHALL FLOWLINE BE LIABLE FOR ANY INCIDENTAL OR CONSEQUENTIAL DAMAGES OF ANY KIND INCLUDING PERSONAL OR REAL PROPERTY OR FOR INJURY TO ANY PERSON. THIS WARRANTY CONSTITUTES THE FINAL, COMPLETE AND EXCLUSIVE STATEMENT OF WARRANTY TERMS AND NO PERSON IS AUTHORIZED TO MAKE ANY OTHER WARRANTIES OR REPRESENTATIONS ON BEHALF OF FLOWLINE. This warranty will be interpreted pursuant to the laws of the State of California. If any portion of this warranty is held to be invalid or unenforceable for any reason, such finding will not invalidate any other provision of this warranty.

For complete product documentation, video training, and technical support, go to [www.flowline.com](http://www.flowline.com).

For phone support, call 562-598-3015 from 8am to 5pm PST, Mon - Fri.

(Please make sure you have the Part and Serial number available.)