

EchoSonic®

Ultrasonic Level Transmitter



FLOWLINE™
LEVEL BEST

LU23, LU27, LU28 & LU29 Series Manual NEMA 6 Enclosure



The EchoSonic® is a general-purpose ultrasonic level transmitter that provides a loop powered 4-20 mA output. The 4-20 mA output can be used to provide the proportional level of liquid in any tank or vessel. The signal can be connected to any device that accepts loop powered 4-20 mA signals, such as a PLC, SCADA, DCS, display, controller, etc.

NEW FEATURES

- Simple configuration with WebCal® software.
- Adjustable Loop Fail-Safe, Hold Last, Empty, Full, 21 mA, 22 mA
- Easy to reverse mA output, 4-20 mA to 20-4 mA
- Adjustable start-up condition, Empty, Mid (12 mA), Full, Over range (22 mA)

TABLE OF CONTENTS

Specifications: 3

Dimensions: 3

About this manual: 4

Components: 5

Getting Started: 6

USB® Fob Interface: 7

Four Steps for Using WebCal®: 8

Step 1: Sensor Configuration: 8

Step 2: Tank Shape Selection: 9

Step 3: Tank Levels Configuration: 9

Step 4: Write to Unit: 10

Wiring: 11

Wiring Diagram: 11

Wiring Connections: 11

Voltage Output: 12

Wiring to Displays, Controller's & PLC's: 13

Installation: 15

Mounting Guide: 15

Installation in Existing Fittings: 15

Metal Tanks: 15

Fitting Selection: 16

Tank Adapter: 16

Riser: 16

Flange: 17

Side Mount Fitting: 17

Stand Pipe: 18

Advanced Feature: 19

Appendix: 20

Updating WebCal® Software: 20

Demo Tab: 20

Factory Defaults: 21

User Settings: 22

Troubleshooting: 23

Warranty: 24

| | | | | |
|-------------------|--|---|---|--|
| Range: | LU27: 4" to 9.8' (10 cm to 3 m) | LU23: 8" to 18.0' (20 cm to 5.5 m) | LU28: 8" to 26.2' (20 cm to 8 m) | LU29: 8" to 32.8' (20 cm to 10 m) |
| Accuracy: | ± 0.2% of range | | Process temp.: | F: -4° to 140° |
| Resolution: | LU27: 0.019" (0.5mm) | LU23: 0.039" (1mm) | Temp. comp.: | C: -20° to 60° |
| | LU28: 0.079" (2 mm) | LU29: 0.079" (2 mm) | Ambient temp.: | F: -31° to 140° |
| Dead band: | LU27: 4" (10cm) | | C: -35° to 60° | |
| | LU23/28/29: 8" (20cm) | | Pressure: | MWP = 30 PSI |
| Beam width: | LU27: 2" (5cm) | | Enclosure type: | Type 6P encapsulated, corrosion resistance & submersible |
| | LU23/28/29: 3" (7.6cm) | | Encl. material: | Polycarbonate |
| Configuration: | WebCal® PC | | Trans. material: | Polyvinylidene Fluoride (PVDF) |
| | Windows® USB® 2.0 | | Cable jacket mat.: | Polyurethane |
| Memory: | Non-volatile | | Cable type: | 4-conductor shielded |
| Supply voltage: | 24 VDC (loop) | | Cable length: | 10' (3 m) |
| Consumption: | 0.5 W | | Process mount: | LU27: 1" NPT (1" G) |
| Loop resistance: | 500 Ohms @ 24 VDC | | | LU23/28/29: 2" NPT (2" G) |
| Signal output: | 4-20 mA, two-wire | | Mount. gasket: | Viton® |
| Signal invert: | 4-20 mA or 20-4 mA | | Classification: | General purpose |
| Signal fail-safe: | 4 mA, 20 mA, 21 mA, 22 mA or hold last | | Compliance: | CE, RoHS |
| | | | Approvals: | cFMus |

DIMENSIONS:

Side View / LU27 Series

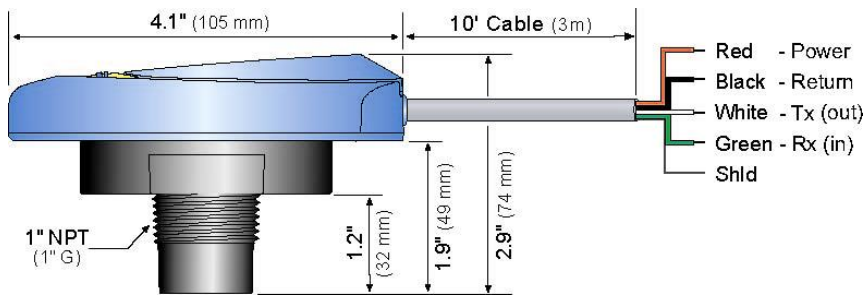

Side View / LU23, LU28 and LU29 Series

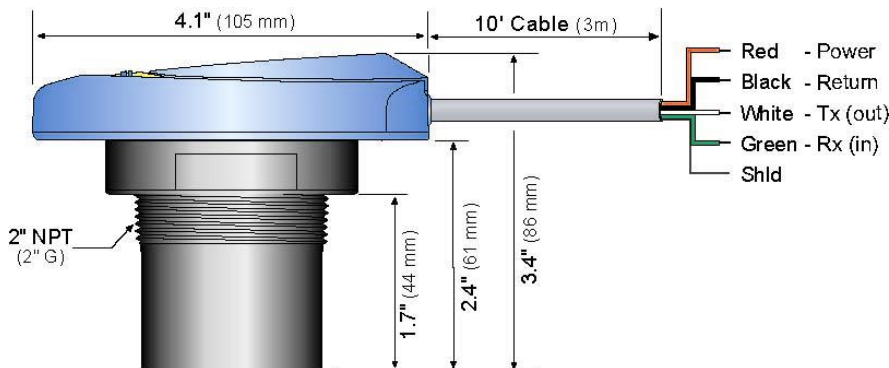

About this Manual: PLEASE READ THE ENTIRE MANUAL PRIOR TO INSTALLING OR USING THIS PRODUCT. This manual includes information on the EchoSonic® series Ultrasonic Level transmitter from FLOWLINE. Please refer to the part number located on the sensor label to verify the exact model configuration, which you have purchased.

- ⚠ **User's Responsibility for Safety:** Flowline manufactures a broad range of level sensing technologies. While each of these sensors is designed to operate in a wide variety of applications, it is the user's responsibility to select a sensor model that is appropriate for the application, install it properly, perform tests of the installed system, and maintain all components. The failure to do so could result in property damage or serious injury.
- ⚠ **Proper Installation and Handling:** Only professional staff should install and/or repair this product. Install the transmitter with the included Viton gasket and never over tighten the transmitter within the fitting. Always check for leaks prior to system start-up.
- ⚠ **Wiring and Electrical:** A supply voltage of 12 to 28 VDC is used to power the EchoSonic®. Electrical wiring of the transmitter should be performed in accordance with all applicable national, state, and local codes.
- ⚠ **Material Compatibility:** The enclosure is made of Polycarbonate (PC). The transducer is made of Polyvinylidene Fluoride (PVDF). Make sure that the model, which you have selected, is chemically compatible with the application media.
- ⚠ **Enclosure:** While the transmitter housing is liquid-resistant the EchoSonic® is not designed to be operational when immersed. It should be mounted in such a way that the enclosure and transducer do not come into contact with the application media under normal operational conditions.
- ⚠ **Safety**
 - Installation should be done by properly trained staff
 - Supply voltage should never exceed a maximum of 28 VDC
 - Make sure the sensor is chemically compatible with your application
 - Design a fail-safe system that accommodates the possibility of sensor and/or power failure.
 - This sensor should not be used in classified hazardous environments
- ⚠ **Make a Fail-Safe System:** Design a fail-safe system that accommodates the possibility of transmitter and/or power failure. FLOWLINE recommends the use of redundant backup systems and alarms in addition to the primary system.

Flammable, Explosive or Hazardous Applications:
EchoSonic® should not be used within classified hazardous environments.

- ⚠ **Warning:** Always use the Viton gasket when installing the EchoSonic®, and make sure that all electrical wiring of the switch is in accordance with applicable codes.

COMPONENTS:

EchoSonic® is offered in four different models. Depending on the model purchased, you may or may not have been shipped all the components shown below. You do however, need an EchoSonic®, USB® Fob and Viton® gasket to configure, install and operate EchoSonic®.

| P/N | Max. Range | Dead Band | Thread | Fob |
|---------|--------------|-----------|--------|--------------|
| LU23-00 | 18.0' (5.5m) | 8" (20cm) | 2" NPT | No Fob |
| LU23-01 | 18.0' (5.5m) | 8" (20cm) | 2" NPT | Fob Included |
| LU23-10 | 18.0' (5.5m) | 8" (20cm) | 2" G | No Fob |
| LU23-11 | 18.0' (5.5m) | 8" (20cm) | 2" G | Fob Included |
| LU27-00 | 9.8' (3m) | 4" (10cm) | 1" NPT | No Fob |
| LU27-01 | 9.8' (3m) | 4" (10cm) | 1" NPT | Fob Included |
| LU27-10 | 9.8' (3m) | 4" (10cm) | 1" G | No Fob |
| LU27-11 | 9.8' (3m) | 4" (10cm) | 1" G | Fob Included |
| LU28-00 | 26.2' (8m) | 8" (20cm) | 2" NPT | No Fob |
| LU28-01 | 26.2' (8m) | 8" (20cm) | 2" NPT | Fob Included |
| LU28-10 | 26.2' (8m) | 8" (20cm) | 2" G | No Fob |
| LU28-11 | 26.2' (8m) | 8" (20cm) | 2" G | Fob Included |
| LU29-00 | 32.8' (10m) | 8" (20cm) | 2" NPT | No Fob |
| LU29-01 | 32.8' (10m) | 8" (20cm) | 2" NPT | Fob Included |
| LU29-10 | 32.8' (10m) | 8" (20cm) | 2" G | No Fob |
| LU29-11 | 32.8' (10m) | 8" (20cm) | 2" G | Fob Included |

- Viton® Gasket
 - Part #200128 for LU27 series
 - Part #200129 for LU23, LU28 or LU29 series
- USB® Fob
 - Part #LI99-1001
- Quick Start Guide

EchoSonic® is configured through WebCal®*, a PC software program. WebCal® is a free download from Flowline’s website. **You must download and install WebCal® prior to plugging in the USB® Fob.** Please go to flowline.com/webcal, and select your language version.



ABOUT PRODUCTS LEVEL TOOLS WHERE TO BUY SUPPORT LITERATURE Q

WebCal® Software

WebCal software is a PC utility program that enables users to easily configure and test compatible Flowline level sensors to their measurement and control requirements. Download your free copy in English or Chinese and connect your sensor through our Fob USB® adapter. Sensors are sold with and without Fobs. When connected to your level sensor, WebCal displays the factory or user configuration that was last written to the sensors non-volatile memory.

System Requirements

- Windows® XP, Vista, 7, 8
- 32 or 64-bit system
- USB® 2.0
- 10 mB hard disk space
- 256 mB RAM

Sensor Configuration



Downloads

- English
 - WebCal Software
 - Manual
- Chinese
 - WebCal 软件



- A** Configure your sensor, update the firmware or demo your configuration prior to installation
- B** Select from preprogrammed drop down menus to create your level configuration
- C** Supports up to 175 sensor configurations
- D** View your sensor part number, serial number, description and firmware
- E** Customize set points to your level measurement or control requirements
- F** Change the proportional signal output from distance to linearized volume using the standard tank shapes or custom strapping table

WEBCAL® SYSTEM REQUIREMENTS:

- Windows® 2000, XP, Vista, 7, 8, 10
- 32 or 64-bit system
- 1 USB® 2.0 port
- 10 mB hard drive space
- 256 mB RAM
- Internet connection

*** For complete information on the WebCal® software, please refer to the WebCal® manual located at flowline.com/webcal.**

USB® FOB INTERFACE:

EchoSonic® communicates with WebCal® through a USB® interface called a Fob. Before plugging your Fob into your computer's USB® port, be sure that you have installed WebCal® on your computer.

Connect the red, green, white and black wires from EchoSonic® into the correct terminals on the Fob. Tighten the screws on the terminals and plug your Fob into the USB® port of your computer.

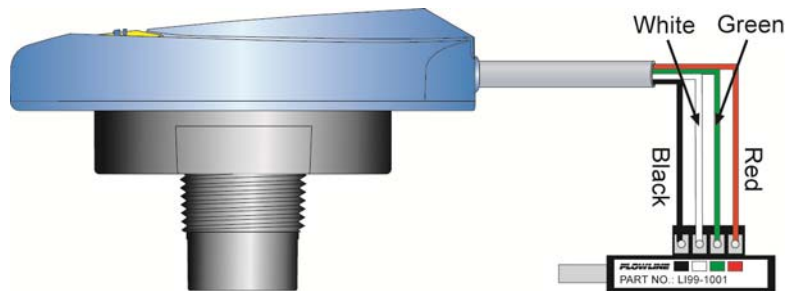
***Wiring identical for all series – Use only the Red, Black, Green and White wires.***

- The maximum cable distance between the computer and EchoSonic® is 15'. This only applies when configuring the EchoSonic®. Otherwise, upon installing the sensor, the maximum cable length is 1,000 feet (Red and Black wires only, minimum 22-gauge).
- Once EchoSonic® is configured and prior to installation, isolate the white and green wires from active power to prevent a short of the configuration circuit
- **Note:** When using the Fob, do not add VDC power. The Fob, when connected to the computer, will provide the required power to the EchoSonic®.

***For complete information on the WebCal® software, please refer to the WebCal® manual located at www.flowline.com/webcal.**

With EchoSonic[®] connected to your computer, open the WebCal[®]* software by clicking on the WebCal[®] icon. Follow steps 1-4 to configure the transmitter. Click “Help” in the lower right hand corner and open the help menu of WebCal[®] for additional instructions on WebCal[®]. If you need additional assistance using WebCal[®], please contact a Flowline applications engineer at (562) 598-3015. * For complete information on the WebCal[®] software, please refer to the WebCal[®] manual located at www.flowline.com/webcal.

CONFIGURING ECHOSONIC[®] WITH WEBCAL[®]

1. Sensor Configuration
 - a. Configures the Loop Fail-Safe, Output at Empty and Startup condition for the sensor.
2. Tank Shape Selection
 - a. Defines the shape of the tank as well as the dimensional information for the tank with respect to the sensor’s location on the tank.
3. Tank Level Configuration
 - a. Enter the settings for the relay activation points as well as confirm the operational range.
4. Write to Unit
 - a. Uploads configuration into the sensor.
 - b. Access to a customer wiring diagram specific to the relay configuration.

SENSOR CONFIGURATION:

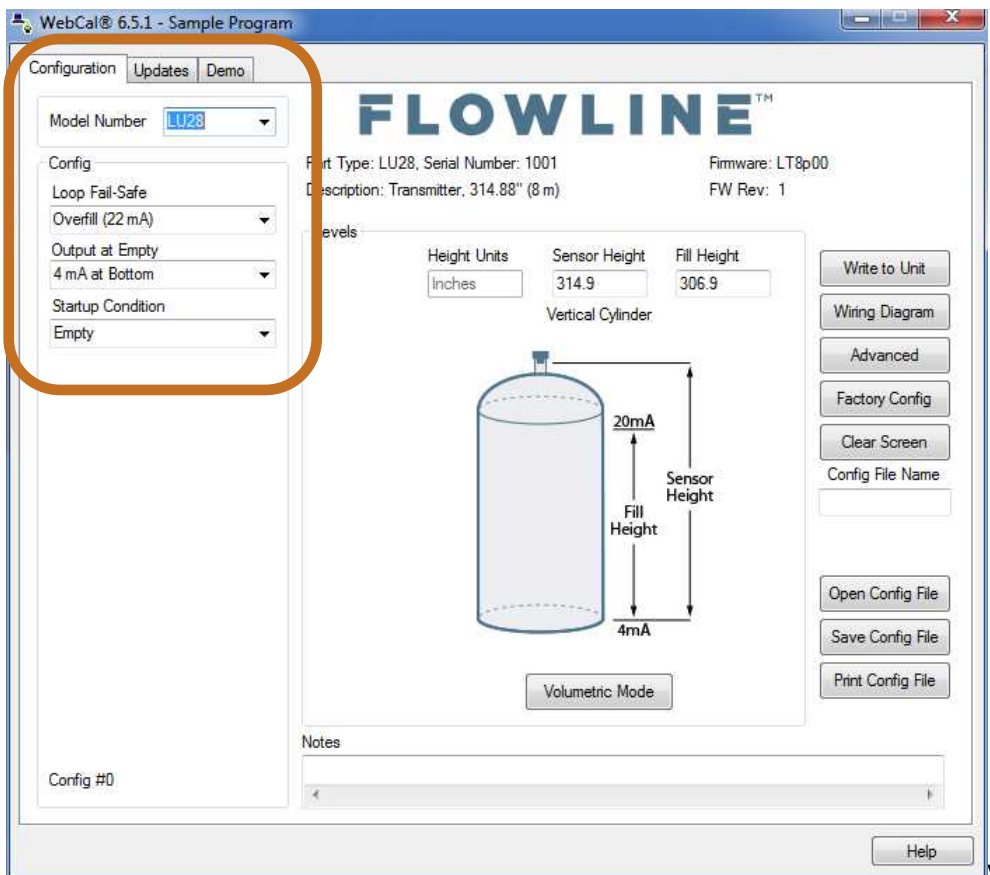

TANK SHAPE SELECTION:

Defines the shape of the tank as well as the dimensional information for the tank with respect to the sensor's location on the tank.

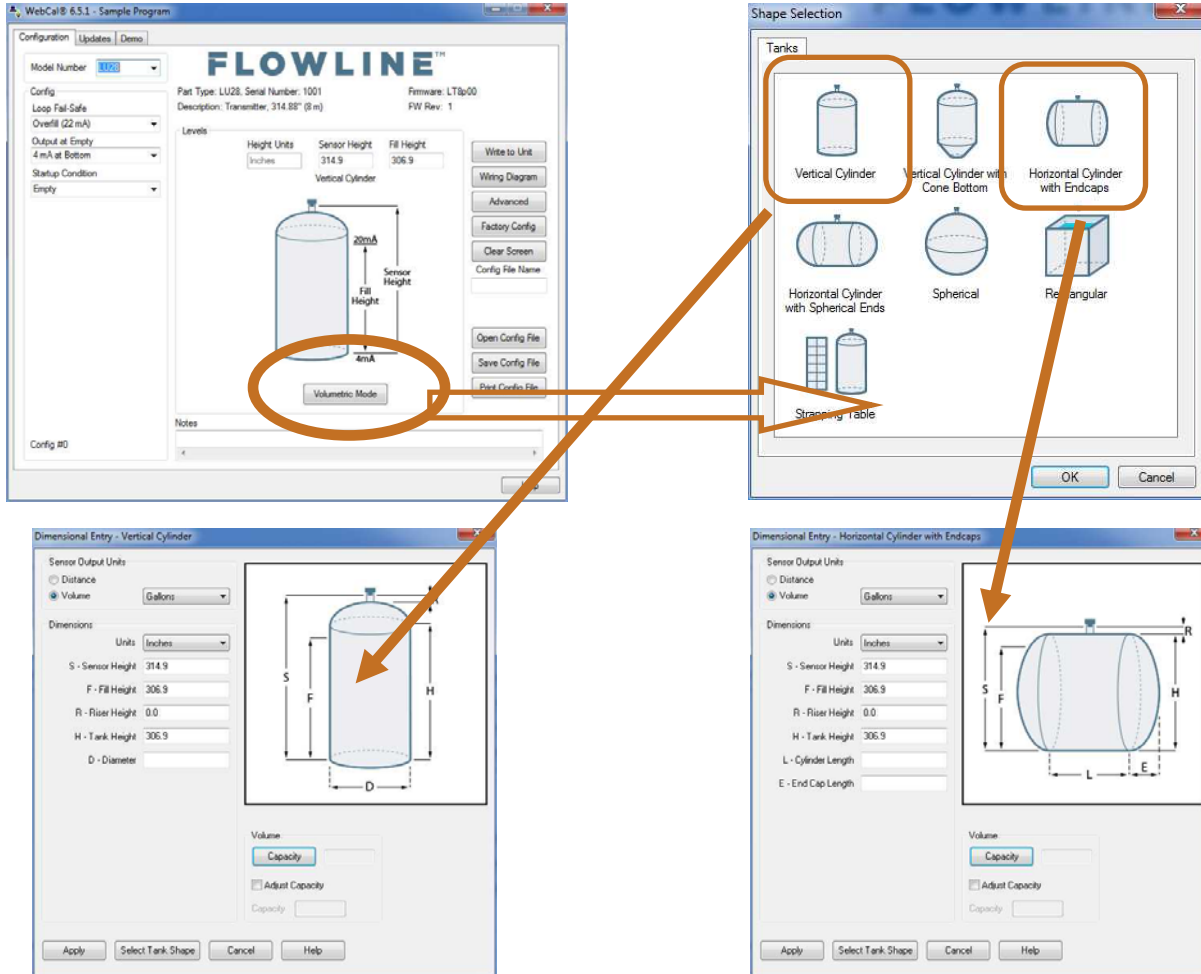

TANK LEVEL CONFIGURATION:

The Height Units, Sensor Height, Fill-Height and Capacity were all calculated in the previous Dimensional Entry window. To adjust these settings, click on **Select Tank Shapes**.

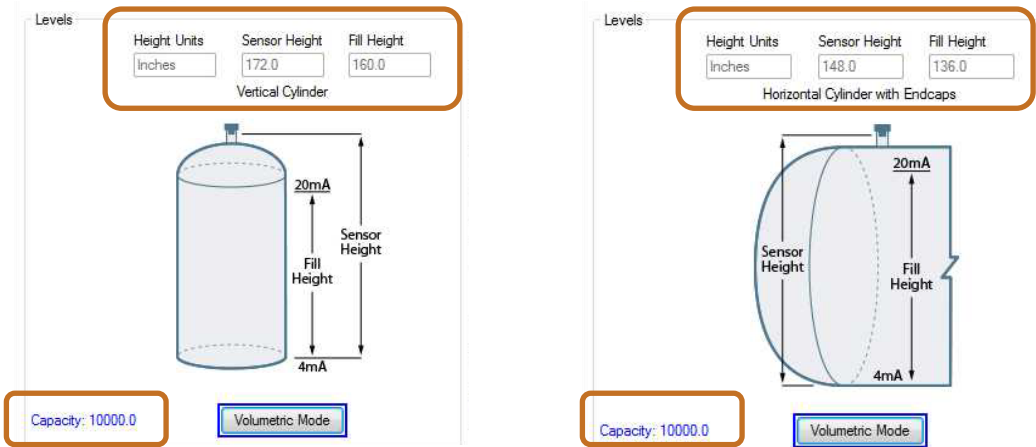

WRITE TO UNIT

This WebCal®* operation uploads configuration into the sensor, provides a custom wiring diagram specific to the signal output, and saves the configuration file to your hard drive.

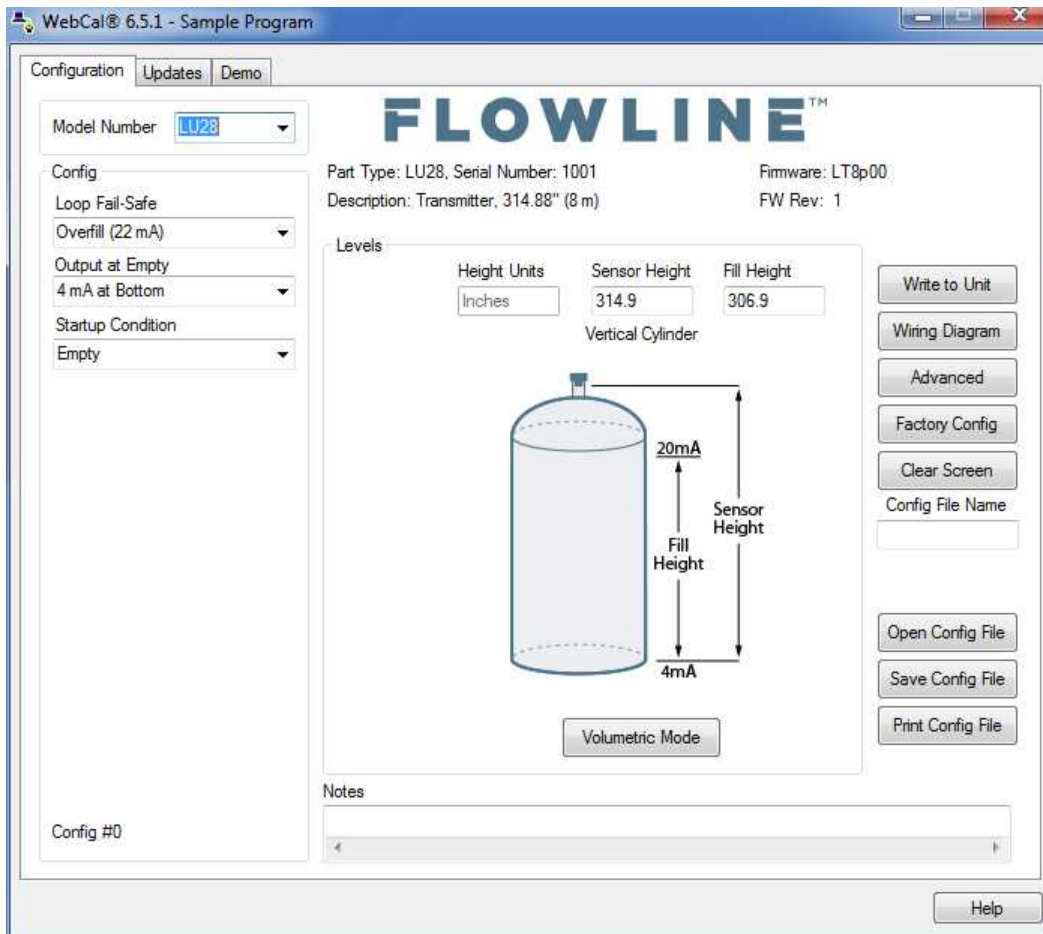

* For complete information on the WebCal® software, please refer to the WebCal® manual located at www.flowline.com/webcal.

WIRING DIAGRAM:

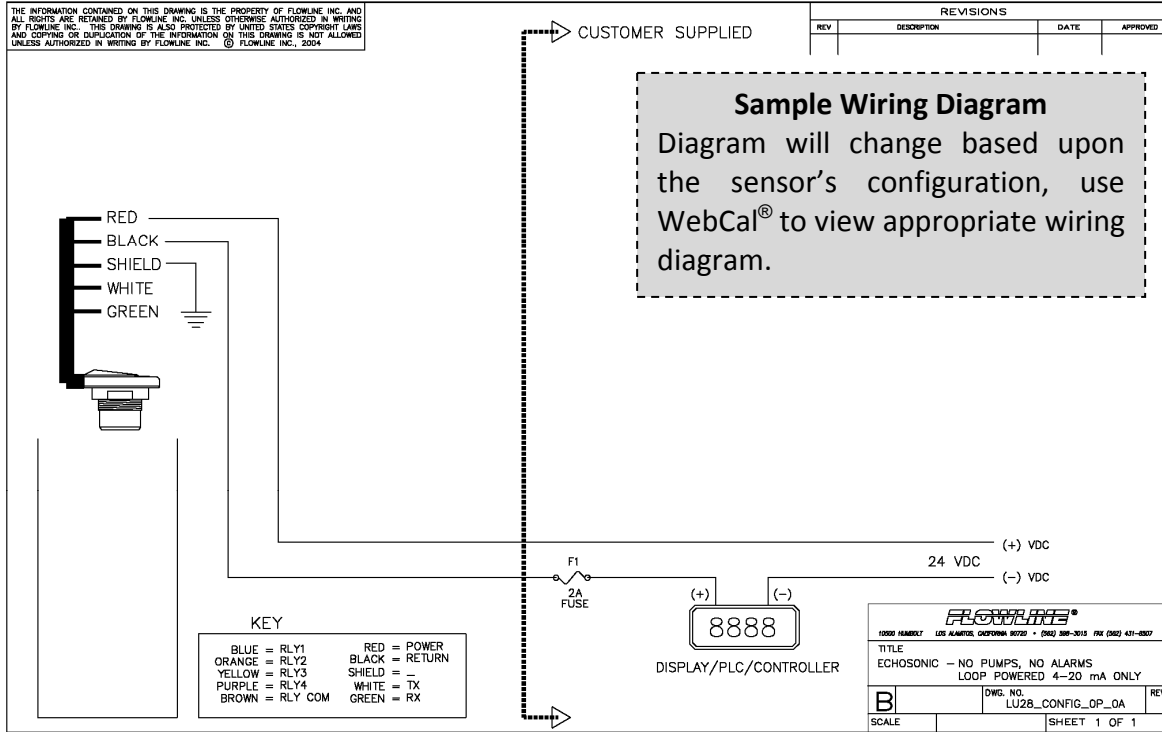

WIRING ECHOSONIC®:

Once EchoSonic® has been configured, follow the Wiring Diagram by the WebCal® software. A typical wiring diagram is shown above. Flowline recommends using a qualified licensed electrician to wire EchoSonic® and your application's components.

WIRE CONNECTIONS:

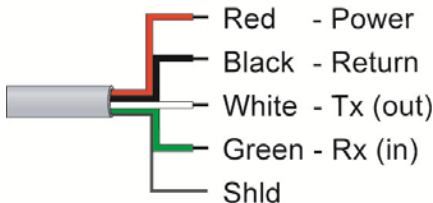

Red & Black: Red (Power) and Black (Return) leads are for connection to a 24 VDC power supply or to a 4-20 mA loop power source. The red and black wires can be extended up to 1,000 feet using a 22 gauge or larger wire; however do not extend the green and white wires beyond 15'.

White & Green: White (TX) and Green (RX) leads are reserved for use with WebCal® and should not be connected during usage in the application. These wires should not be connected to WebCal® while power is supplied from any source other than the LI99 series Fob. The maximum cable distance between the computer and EchoSonic® is 15'.

Never allow the white or green wires to touch any power supply.

GENERAL NOTES FOR ELECTRICAL CONNECTIONS, USAGE AND SAFETY:

- **Where personal safety or significant property damage can occur due to a spill, the installation must have a redundant backup safety system installed.**
- Wiring should always be completed by a licensed electrician.
- Supply voltage should never exceed 28 VDC.
- Protect the sensor from excessive electrical spikes by isolating the power, whenever possible.
- The sensor materials must be chemically compatible with the liquids to be measured.
- Design a fail-safe system for possible sensor and/or power failure.
- **Never use the sensor in environments classified as hazardous.**

VOLTAGE OUTPUT:

EchoSonic® can be used as a 0 to 5 or 0 to 10 VDC output device. A resistor will need to be added to the circuit to enable a voltage output (refer to the wiring diagram below).

- 0-5 VDC output
 - Add a 250 Ohm resistor
 - Actual output will be 0.8 to 5 VDC
- 0-10 VDC output
 - Add a 500 Ohm resistor
 - Actual output will be 2 to 10 VDC

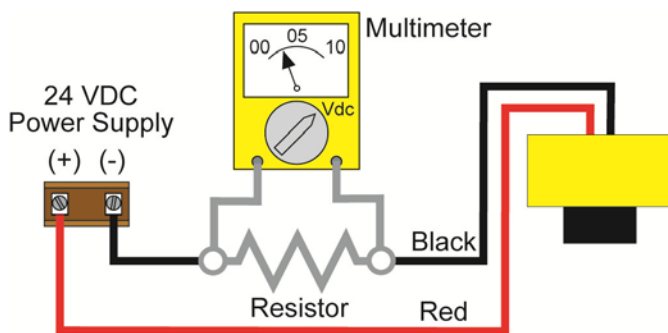

WIRING TO DISPLAY, CONTROLLERS & PLC'S

Below is a quick review of wiring the EchoSonic® to common display, controllers and PLC's.

**DataView™ LI55 Series
Level Controller**

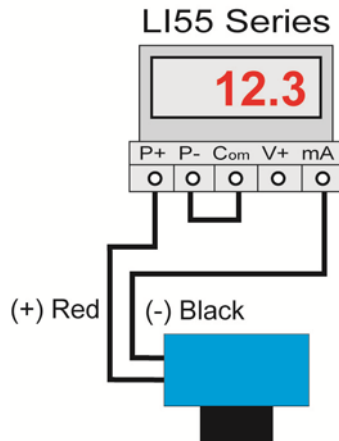

**Commander™ LI90 Series
Multi-Tank Level Controller**

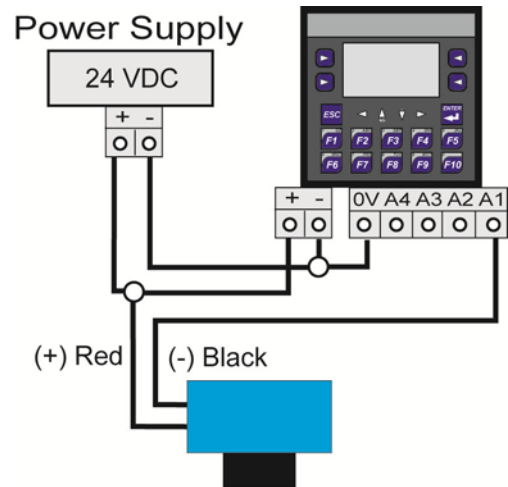

**DataLoop™ LI25 Series
Level Indicator
without the backlight**

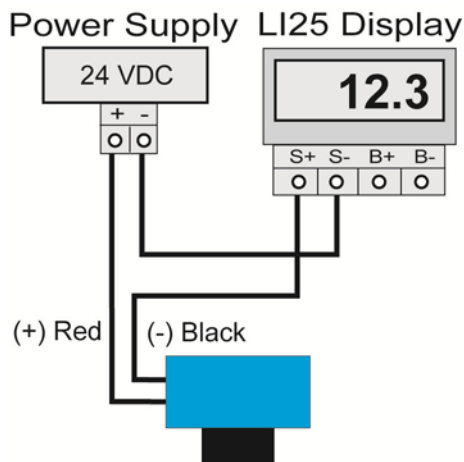

**DataLoop™ LI25 Series
Level Indicator
with the backlight**

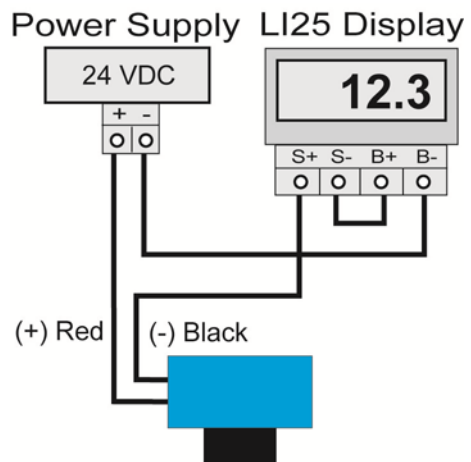

WIRING TO DISPLAY, CONTROLLERS & PLC'S (CONTINUED)

**DataPoint™ LC52 Series
Level Controller
*JWA mode (Factory Setting)**

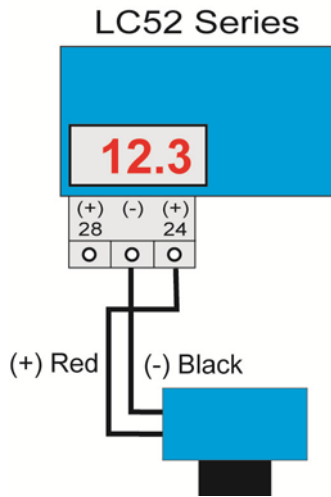

**DataPoint™ LC52 Series
Level Controller
*JWB mode**

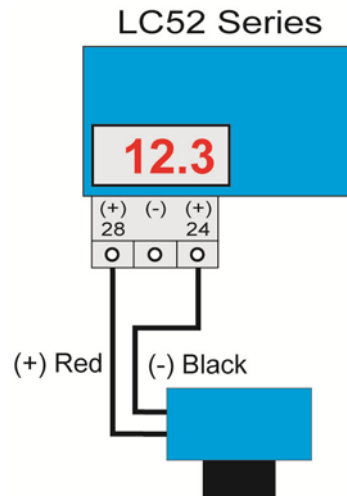

**Generic Loop
Powered Display**

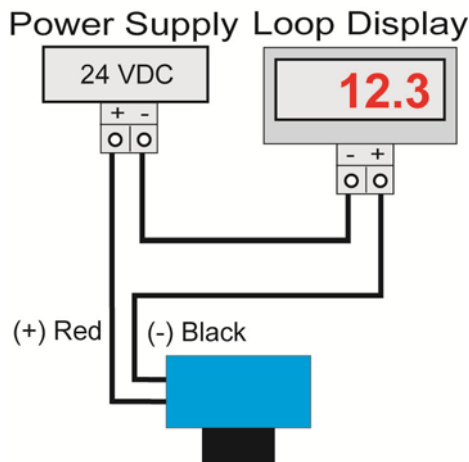

Generic PLC

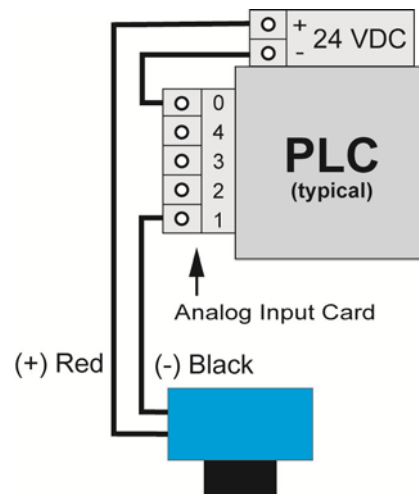

* Refer to the DataPoint™, LC52 Series, Level Controller manual for information on JWA mode and JWB mode settings in the controller.

The EchoSonic® should always be mounted perpendicular to the liquid surface and installed using the provided Viton mounting gasket. Make sure that the fitting and transmitter threads are not damaged or worn. Always **hand-tighten** the transmitter within the fitting. Perform an installed leak test under normal process conditions prior to system start up. **Note: The preferred mounting fitting for the LU27 series is the LM52-1400 (2" thread x 1" thread) reducer bushing.**

MOUNTING GUIDE

1. Do not mount at an angle
2. Liquid should never enter the dead band
3. Side Wall:
 - a. Mount at least 3" from the side wall
 - b. For LU27 Series - mount at least 2" from the side wall
4. Do not mount where obstacles will intrude on sensor's beam width
 - a. For LU27 Series - mount at least 2" from the side wall
 - b. For LU23, LU28 & LU29 Series - mount at least 3" from the side wall
5. Do not mount in a vacuum
6. Avoid mounting in the center of a dome top tank.
7. In cone bottom tank, position the sensor over the deepest part of the tank.

INSTALLATION IN EXISTING FITTINGS:

If the existing fitting is larger than the threads of the EchoSonic®, select a reducer bushing such as the LM52-1400 (2" thread x 1" thread) or LM52-2400 (3" thread x 2" thread).



LM52-1400



LM52-2400

METAL TANKS (LU27 SERIES ONLY):

The LU27 series has been optimized for use in non-metallic fittings.

1. For best performance, avoid the use of metallic fittings.
 - a. Use a plastic 2" x 1" reducer bushing, such as the LM52-1400 or a plastic 1" flange, such as the LM52-1850 for metallic tanks.
2. While installations directly into a 1" metal fitting are not recommended, acceptable results may be obtained if the 1" fitting is a half coupling in form and the outer diameter of the coupling is tightly wrapped in vinyl tape to dampen vibrations.

| | |
|---|--|
| <p><i>Do not install at angle relative to the liquid.</i></p> | |
| <p><i>Do not install within 3" of tank sidewall.</i></p> | |
| <p><i>Do not install with objects in the beam.</i></p> | |
| <p><i>Do not install in applications with vacuum.</i></p> | |

FITTING SELECTION:

Check the part number to determine the required fitting mount size and thread type. EchoSonic® is commonly installed in tank adapters, flanges, brackets or standpipes. Note: Always include the gasket when installing the EchoSonic®.

1. **Tank Adapter:** Select a tank adapter fitting, such as the LM52-1890 for the LU27 series or the LM52-2890 for the LU23, LU28 & LU29 series.
 - a. For best results, select a 2" tank adapter and add a reducer bushing such as the LM52-1400, thread x thread, reducer bushing.
 - b. Avoid tank adapter (thread x thread) styles and/or pipe stops forward of the installed transducer.
 - c. Always mount the tank adapter so the majority of fitting is outside the tank.
 - i. **Note:** Never mount the tank adapter upside down or where the bulk of the material is inside the tank.

**2" Tank Adapter
Socket x Thread
(LM52-2890)**



**Tank Adapter
w/ 2"x1" Reducer Bushing
LM52-2890 w/LM52-1800)**



**Tank Adapter
Thread x Thread**



Do not use thread x thread

2. **Riser:** Installations with tall, narrow risers can impede the acoustic signal.
 - a. **Core Out Concrete:** Applications where tank with a concrete ceiling that has been cored out can also be considered as a riser type application. In these applications follow a 2:1 ratio (Inner Diameter to Core Height) for the diameter of the core.
 - a. **LU23, LU28 & LU29 Series:** 2" (5 cm) diameter risers should be no taller than 5" (12.7 cm). Larger diameter risers should be no taller than 12" (30.5 cm).
 - b. **LU27 Series:**

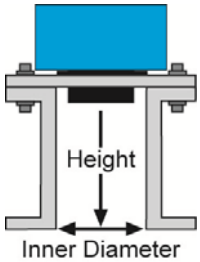
|  | Riser Specifications | |
|---|----------------------|----------------|
| | Inner Diameter | Maximum Height |
| | 2" (5cm) | 3" (7.6cm) |
| | 4" (10cm) | 8" (20cm) |
| | 6" (15cm) | 12" (30cm) |



Note: If attempting to raise the sensor above the top of the tank to allow for a higher fill capacity, avoid the use of tall and narrow risers. The example to the left exceeds the dimensions listed in the **Riser Specifications** chart. Use a larger tank adapter which takes into account the **Riser Specifications**.

Note: Do not exceed the dimensions listed above.

Flange (LU27 series): If installing on a flange, select a flange with a thread that is above the plane of the flange, such as the LM52-1850.

- a. The LU23, LU28 & LU29 series works well with Flange installations.
- b. Avoid the use of blind flanges with tapped threads or flanges where the threads are even with the plane of the flange, such as the Banjo 1" Poly ANSI Flange (series AF100).
- c. Use a flange with a 2" thread and add a 2" to 1" reducer bushing to complete the installation for the LU27 series.



- 3. **Side Mount Bracket:** For installations in open tanks and sumps, use the LM50 series side mount bracket.
 - a. For the LU27 series, order the LM50-1001-1, which includes a 2"x 1" Reducer Bushing.
 - b. For the LU23, LU28 & LU29, series, order the LM50-1001 side mount bracket.

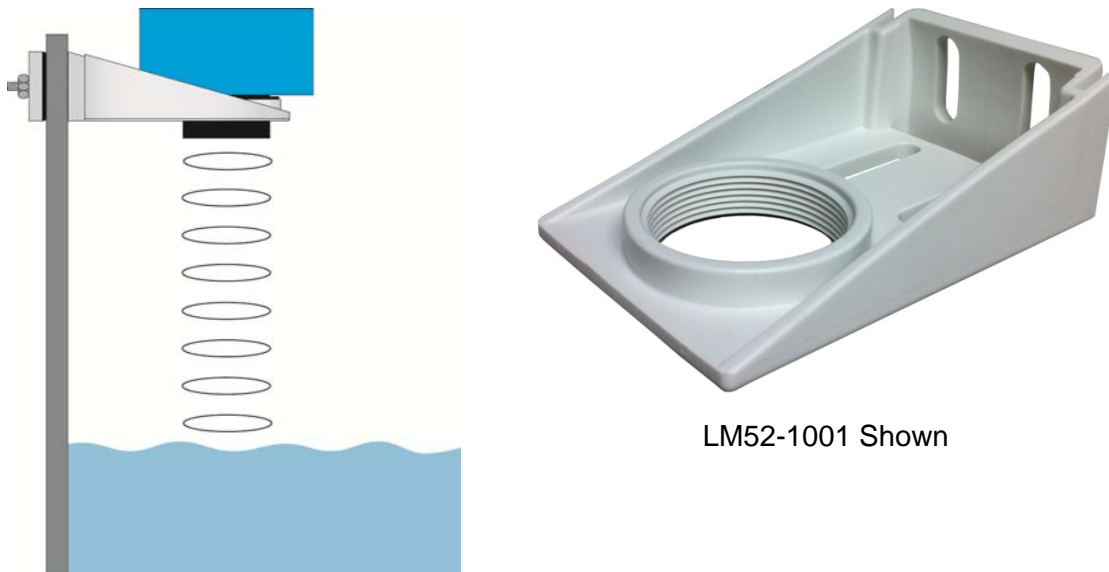

Note: The Side Mount Bracket (LM50 series) is not designed for use with stand pipes or as a method to secure stand pipes. There are too few threads to properly hold the sensor and the stand pipe.

Stand Pipe: A standpipe maybe used to dampen turbulence or when foam is present in the application.

- a. Pipe can be made of any material.
- b. Minimum ID for the stand pipe is listed below.
 - i. A 2" pipe (min. pipe ID) is usable with the LU27 series.
 - ii. A 3" pipe (min. pipe ID) is usable with the LU23, LU28 & LU29 series.
 - iii. Pipes larger than 3" can also be used.
- c. Use a coupling and reducer bushing to attach the EchoSonic® to the pipe.
 - i. With the LU27 series, be sure to use a plastic reducing bushing such as LM52-1400 2" T x 1" T fitting or the LM52-1410 2" S x 1" T fitting.
 - ii. For the LU27 series, be sure to use a plastic reducing bushing such as LM52-1400 (2"T x 1"T) fitting or the LM52-1410 (2"S x 1"T) fitting.
 - iii. For the LU23, LU28 & LU29 series, use a reducer bushing such as LM52-2400 (3"T x 2"T) fitting or the LM52-2410 (3"S x 2"T) fitting.
- d. The pipe length should run the measurement span and the bottom of the pipe should remain submerged at all times to prevent foam from entering the pipe.
- e. Cut a 45° notch at the bottom of the pipe and drill a 1/4" pressure equalization hole in the dead band.
- f. The pumps should not drive liquid past the open end of the stand pipe which causes the liquid in the pipe to oscillate.

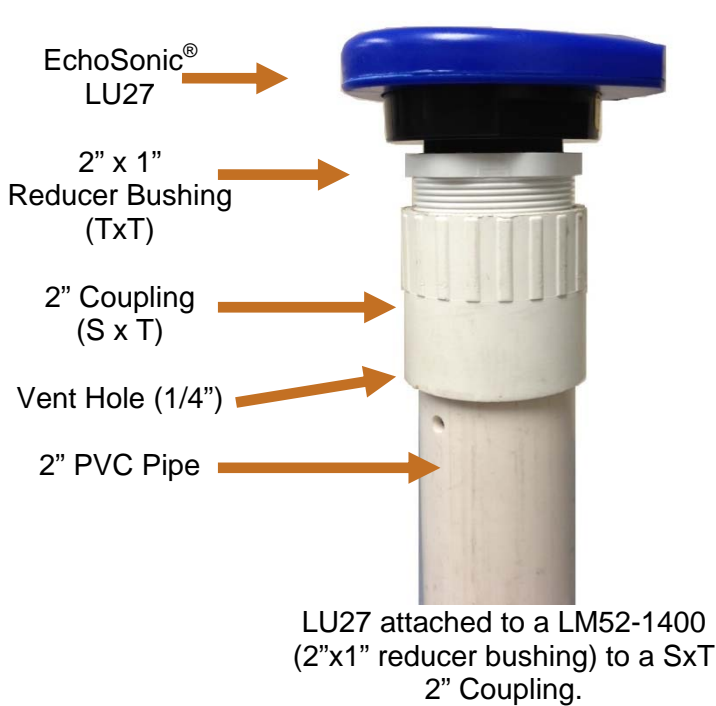
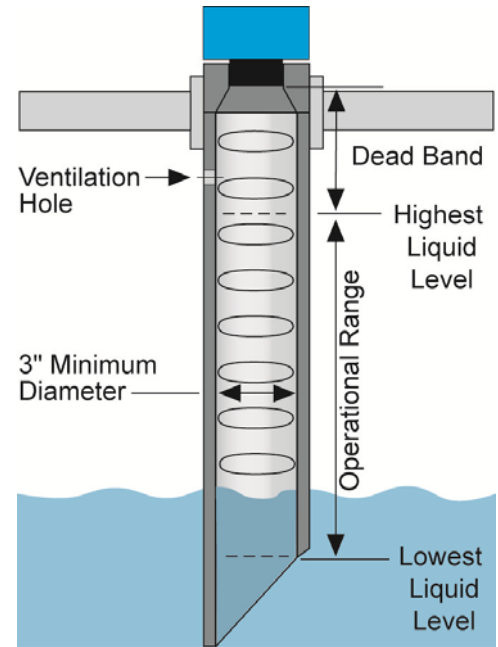

Avoid the use of a tee within the stand pipe. A tee can create false signals which will interfere with the sensor's performance.

This tool is designed to help solve operational issues. Changing these setting will alter the performance of your unit. Please read through this HELP file to assist you in making adjustments or if still unclear about a specific issue, please contact FLOWLINE, Applications Engineering.

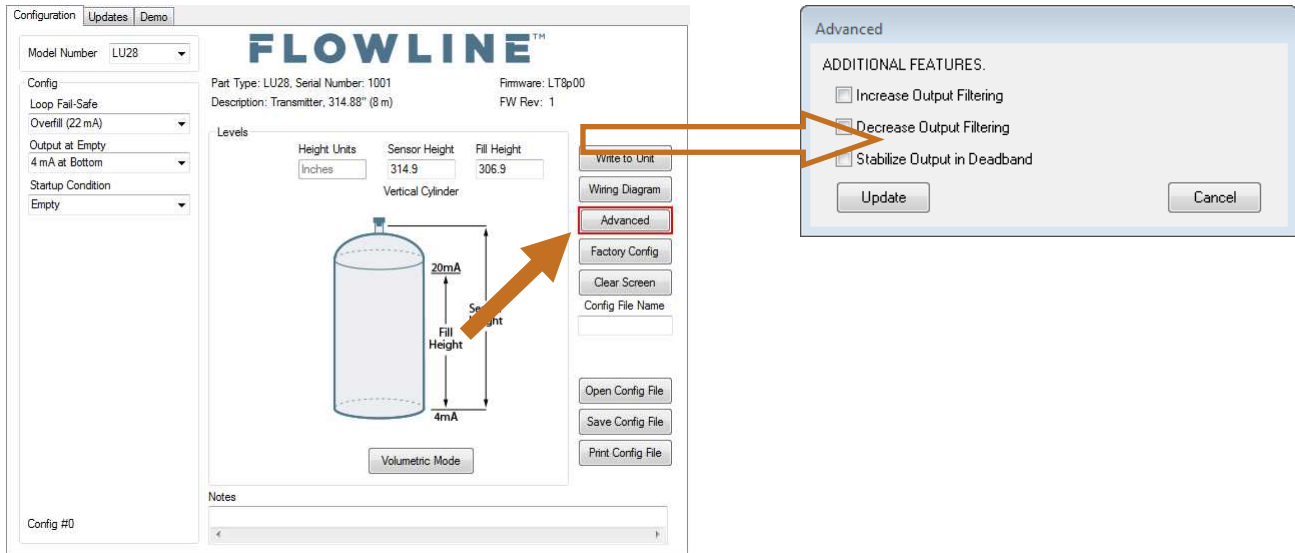

NOTE: When the Advanced Button is highlighted with a RED border, this indicates you have selected an advanced feature...

- **Increase Output Filtering:** Placing a check mark in the box will increase the filtering (averaging) of the analog output. Use this filter if the 4 to 20 mA output requires a smooth output for the application such as open channel flow measurement.
- **Decrease Output Filtering:** Placing a check mark in the box will eliminate all filtering (averaging) of the analog output. Enables a pulse by pulse level reading. Use this filter to see changes in level after every sound pulse.

Note: Never check increase output filtering and decrease output filtering at the same time.

- **Stabilize Output in Dead band:** Placing a check mark in the box will activate a filter to hold the output at Full if the level enters the dead band of the EchoSonic®. This filter requires the level to leave the dead band at a smooth and steady rate.

UPDATE AND DEMO TABS:

WebCal® has two other page tabs which can be used to assist in the configuration of the EchoSonic®. These page tabs are the Updates and Demo tabs.

- **Updates:** The Updates tab has two key features. The first is the ability to update the WebCal® software to its latest version. The second is the ability to update EchoSonic®'s firmware to its latest version.
- **Demo:** The Demo tab has the ability to test the EchoSonic® sensor against a fixed target.

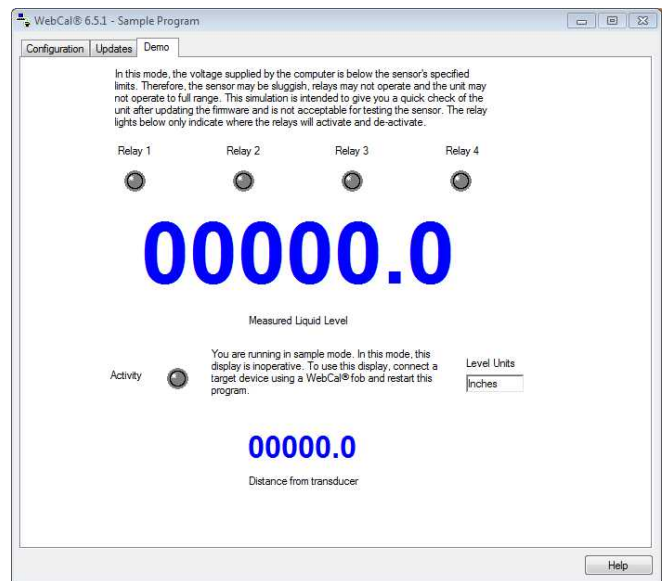
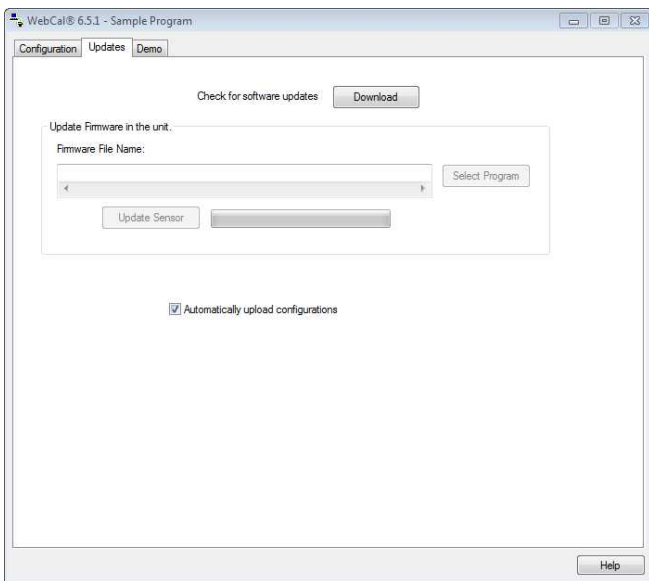
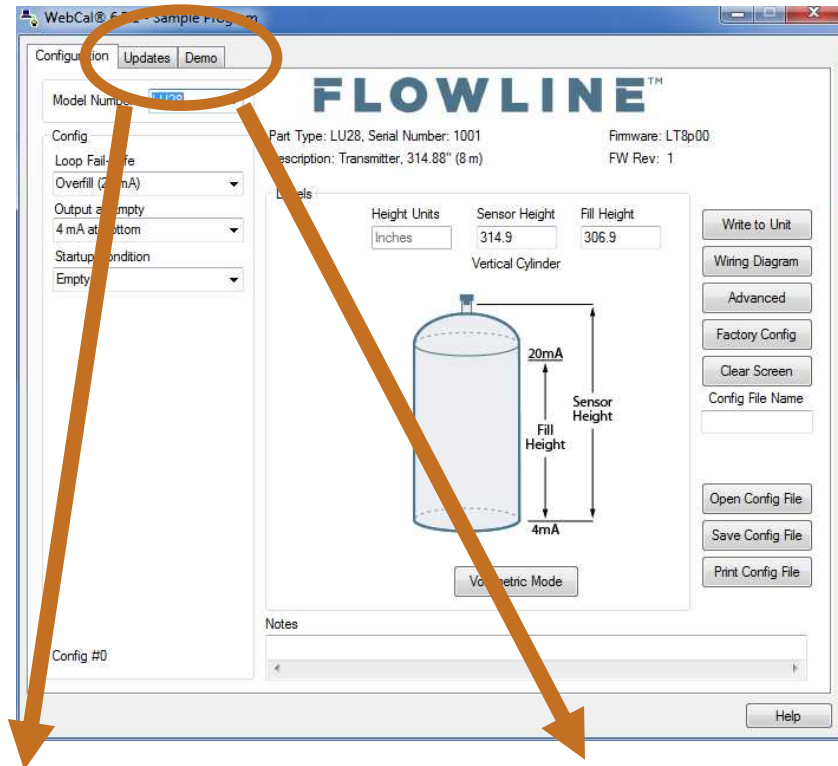

FACTORY DEFAULT:

Pressing the Factory Config button in the Configuration menu will return the screen to the following settings. Out of the box, the EchoSonic® will output a 4-20 mA output that is maximized for its operational range. The transmitter can be used in the original factory setting without configuration with WebCal®. Use the table below to identify the configuration of the sensor out of the box.

Factory Defaults Table

| Part Number | Sensor Height | Fill Height | Loop Fail-Safe | Output at Empty | Startup Condition |
|----------------|------------------|-----------------|------------------|-----------------|-------------------|
| LU27-__ Series | 300 cm (118.1") | 290 cm (114.1") | Overfill (22 mA) | 4 mA @ Bottom | Empty |
| LU23-__ Series | 550 cm (216.5") | 530 cm (208.7") | Overfill (22 mA) | 4 mA @ Bottom | Empty |
| LU28-__ Series | 800 cm (315.0") | 780 cm (307.1") | Overfill (22 mA) | 4 mA @ Bottom | Empty |
| LU29-__ Series | 1000 cm (393.7") | 980 cm (385.8") | Overfill (22 mA) | 4 mA @ Bottom | Empty |

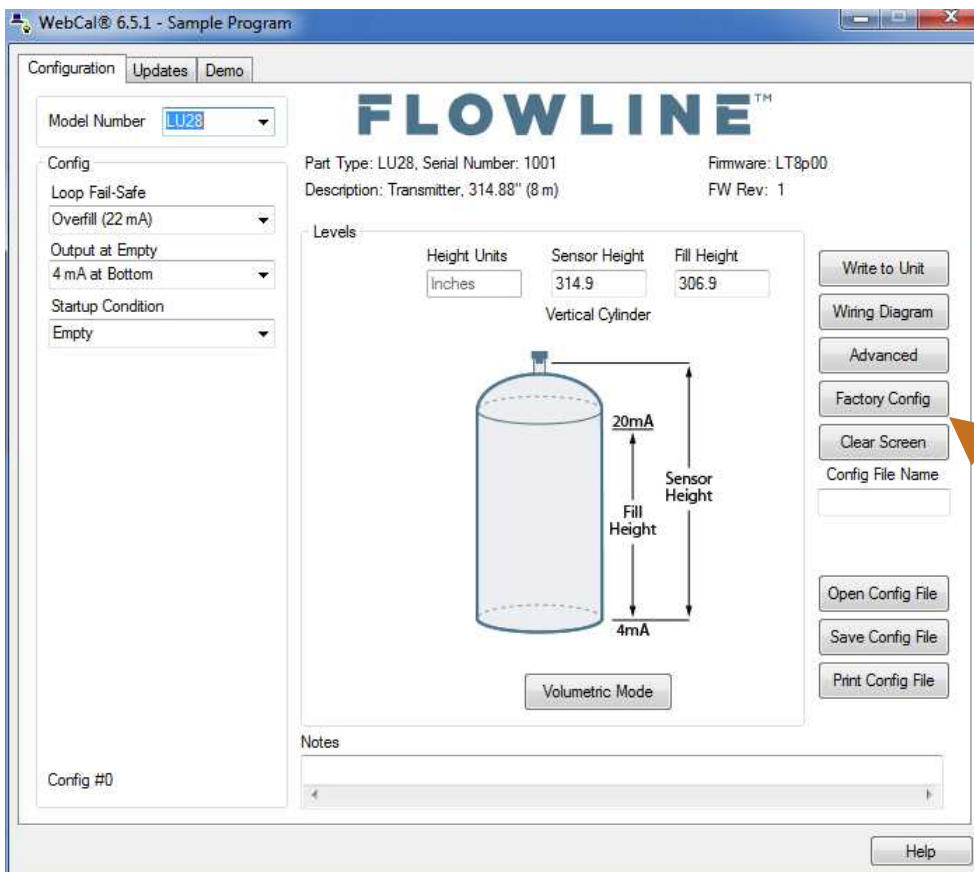

TESTING THE TRANSMITTER:

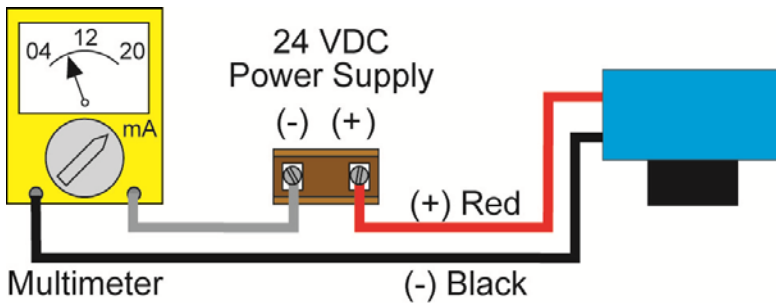

1. Connect a multimeter in series with the black wire to read the current output.
2. Verify that the current increases (tank filling) and decreases (tank emptying) appropriately in the calibrated span.
3. If not, carefully observe and attempt to correlate any installation, level or application event for more specific troubleshooting direction.

USER SETTINGS:

Fill out the chart below and keep as a record of your configuration.

Tank

| | |
|----------|----------|
| Height = | Fill-H = |
|----------|----------|

Loop Fail-Safe (select one)

| | | | | |
|-----------------|-------|------|-----------------|-----------------|
| Hold Last Value | Empty | Full | Overfill (21mA) | Overfill (22mA) |
|-----------------|-------|------|-----------------|-----------------|

Output at Empty (select one)

| | |
|---------------|----------------|
| 4mA at Bottom | 20mA at Bottom |
|---------------|----------------|

Startup Condition (select one)

| | | | |
|-------|-----------------|-----------|-----------------|
| Empty | Mid-Tank (12mA) | Full Tank | Overfill (22mA) |
|-------|-----------------|-----------|-----------------|

Advanced (if selected, identify which filter that was activated)

| | | |
|----------------------------|----------------------------|-------------------------------|
| Increase output filtering: | Decrease output filtering: | Stabilize output in dead band |
|----------------------------|----------------------------|-------------------------------|

TROUBLESHOOTING:

| PROBLEM | SOLUTION |
|---|---|
| Transmitter indicates a current of 0 mA | Check the EchoSonic [®] wiring for an open circuit. An open circuit is the most common issue with a 0 mA signal. |
| Transmitter jumps to a current reading between 19 and 20 mA | Check the EchoSonic [®] installation. Bad installation fittings will cause false signals near the top of the tank, which typically translates to a signal between 19 and 20 mA. Also look for interference just below the transmitter. If the transmitter is installed in a metal fitting, switch to a plastic fitting. |
| Transmitter indicates a current over 23 mA | Check the wiring for a short circuit. The EchoSonic [®] is current limited to 22 mA. Anything above 22 mA indicates a short circuit. |
| Transmitter always jumps to LOST condition | Check the dimensional configuration (Sensor Height and Fill-Height) of the EchoSonic [®] . Make sure that the Fill-H setting corresponds to the full level of liquid (from the bottom up) and not the distance from the transmitter to the liquid (top down). |
| Output of transmitter is opposite of the level of liquid | Check the Output at Empty Setting. |
| No Unit Detected in WebCal [®] | WebCal [®] cannot detect an EchoSonic [®] connected to the computer. <ul style="list-style-type: none"> • Check that the Fob is connected to the USB[®] port. • Check that all four wires (Red, Black, White and Green) are securely attached to the Fob. • Check in Device Manager that both drivers (WebCal[®] Configuration & EchoFob) are present. |
| Internet error. The server name or address could not be resolved. | This is a warning indicating the computer configuring EchoSonic [®] is not connected to the internet. Click OK to continue. Flowline recommends being connecting to the internet for all configurations. Not being connected to the internet will not prevent the EchoSonic [®] from being configured. |
| Cannot access some of the features in Configuration | As choices are made in Configuration, WebCal [®] will begin to eliminate functions that are not applicable to a configuration. To reset Configuration or get access to all the features, click on the Clear Screen button. |

WARRANTY

Flowline warrants to the original purchaser of its products that such products will be free from defects in material and workmanship under normal use and service in accordance with instructions furnished by Flowline for a period of two years from the date of manufacture of such products. Flowline's obligation under this warranty is solely and exclusively limited to the repair or replacement, at Flowline's option, of the products or components, which Flowline's examination determines to its satisfaction to be defective in material or workmanship within the warranty period. Flowline must be notified pursuant to the instructions below of any claim under this warranty within thirty (30) days of any claimed lack of conformity of the product. Any product repaired under this warranty will be warranted only for the remainder of the original warranty period. Any product provided as a replacement under this warranty will be warranted for the full two years from the date of manufacture.

RETURNS

Products cannot be returned to Flowline without Flowline's prior authorization. To return a product that is thought to be defective, go to flowline.com, and submit a customer return (MRA) request form and follow the instructions therein. All warranty and non-warranty product returns to Flowline must be shipped prepaid and insured. Flowline will not be responsible for any products lost or damaged in shipment.

LIMITATIONS

This warranty does not apply to products which: 1) are beyond the warranty period or are products for which the original purchaser does not follow the warranty procedures outlined above; 2) have been subjected to electrical, mechanical or chemical damage due to improper, accidental or negligent use; 3) have been modified or altered; 4) anyone other than service personnel authorized by Flowline have attempted to repair; 5) have been involved in accidents or natural disasters; or 6) are damaged during return shipment to Flowline. Flowline reserves the right to unilaterally waive this warranty and dispose of any product returned to Flowline where: 1) there is evidence of a potentially hazardous material present with the product; or 2) the product has remained unclaimed at Flowline for more than 30 days after Flowline has dutifully requested disposition. This warranty contains the sole express warranty made by Flowline in connection with its products. **ALL IMPLIED WARRANTIES, INCLUDING WITHOUT LIMITATION, THE WARRANTIES OF MERCHANTABILITY AND FITNESS FOR A PARTICULAR PURPOSE, ARE EXPRESSLY DISCLAIMED.** The remedies of repair or replacement as stated above are the exclusive remedies for the breach of this warranty. **IN NO EVENT SHALL FLOWLINE BE LIABLE FOR ANY INCIDENTAL OR CONSEQUENTIAL DAMAGES OF ANY KIND INCLUDING PERSONAL OR REAL PROPERTY OR FOR INJURY TO ANY PERSON. THIS WARRANTY CONSTITUTES THE FINAL, COMPLETE AND EXCLUSIVE STATEMENT OF WARRANTY TERMS AND NO PERSON IS AUTHORIZED TO MAKE ANY OTHER WARRANTIES OR REPRESENTATIONS ON BEHALF OF FLOWLINE.** This warranty will be interpreted pursuant to the laws of the State of California. If any portion of this warranty is held to be invalid or unenforceable for any reason, such finding will not invalidate any other provision of this warranty.

For complete product documentation, video training, and technical support, go to flowline.com.
For phone support, call 562-598-3015 from 8am to 5pm PST, Mon - Fri.
(Please make sure you have the Part and Serial number available.)