

Warranty, Service & Repair

To register your product with the manufacturer, go to the Flowline website for on-line registration. The website address is as follows:

www.flowline.com

On-line Warranty Registration can be found under Contact Flowline on the Navigation Bar along the side of the home page.

If for some reason your product must be returned for factory service, go to the Flowline website listed above. Online Factory Service can be found under Contact Flowline on the Navigation Bar along the side of the home page. Click on **Return Authorization** to begin the registration process. You will need the following information at the time of registration:

1. Part Number and full Serial Number from product
2. Name and telephone number of someone who can answer technical questions related to the product and its application.
3. Return Shipping Address
4. Brief Description of the Symptom
5. Brief Description of the Application

Once you have received a Material Return Authorization number, ship the product prepaid in its original packing to:

Flowline Factory Service
MRA _____
10500 Humbolt Street
Los Alamitos, CA 90720

To avoid delays in processing your repair, write the MRA on the shipping label. Please include the information about the malfunction with your product. This information enables our service technicians to process your repair order as quickly as possible.

FLOWLINE®

Compact Relay Controller LC10 and LC11 Series Owner's Manual



Version 5.2A

© 2007 FLOWLINE Inc.

All rights reserved.

Manual # MNC 11100 09/07

WARRANTY

Flowline warrants to the original purchaser of its products that such products will be free from defects in material and workmanship under normal use and service for a period which is equal to the shorter of one year from the date of purchase of such products or two years from the date of manufacture of such products.

This warranty covers only those components of the products which are non-moving and not subject to normal wear. Moreover, products which are modified or altered, and electrical cables which are cut to length during installation are not covered by this warranty.

Flowline's obligation under this warranty is solely and exclusively limited to the repair or replacement, at Flowline's option, of the products (or components thereof) which Flowline's examination proves to its satisfaction to be defective. FLOWLINE SHALL HAVE NO OBLIGATION FOR CONSEQUENTIAL DAMAGES TO PERSONAL OR REAL PROPERTY, OR FOR INJURY TO ANY PERSON.

This warranty does not apply to products which have been subject to electrical or chemical damage due to improper use, accident, negligence, abuse or misuse. Abuse shall be assumed when indicated by electrical damage to relays, reed switches or other components. The warranty does not apply to products which are damaged during shipment back to Flowline's factory or designated service center or are returned without the original casing on the products. Moreover, this warranty becomes immediately null and void if anyone other than service personnel authorized by Flowline attempts to repair the defective products.

Products which are thought to be defective must be shipped prepaid and insured to Flowline's factory or a designated service center (the identity and address of which will be provided upon request) within 30 days of the discovery of the defect. Such defective products must be accompanied by proof of the date of purchase.

Flowline further reserves the right to unilaterally waive this warranty and to dispose of any product returned to Flowline where:

- a. There is evidence of a potentially hazardous material present with product.
- b. The product has remained unclaimed at Flowline for longer than 30 days after dutifully requesting disposition of the product.

THERE ARE NO WARRANTIES WHICH EXTEND BEYOND THE DESCRIPTION ON THE FACE OF THIS WARRANTY. This warranty and the obligations and liabilities of Flowline under it are exclusive and instead of, and the original purchaser hereby waives, all other remedies, warranties, guarantees or liabilities, express or implied. EXCLUDED FROM THIS WARRANTY IS THE IMPLIED WARRANTY OF FITNESS OF THE PRODUCTS FOR A PARTICULAR PURPOSE OR USE AND THE IMPLIED WARRANTY OF MERCHANTABILITY OF THE PRODUCTS.

This warranty may not be extended, altered or varied except by a written instrument signed by a duly-authorized officer of Flowline, Inc.

SPECIFICATIONS

Step One

Supply voltage:	120 / 240 VAC, 50 - 60 Hz.
Consumption:	5 Watts max.
Strobe type:	10_1: N/A 10_2: Xenon tube
Strobe flash:	10_1: N/A 10_2: 1 per second
Sensor inputs:	LC10: (1) two-wire level switch LC11: (2) two-wire level switches
Sensor supply:	13.5 VDC @ 27 mA
Contact type:	LC10: (1) SPDT LC11: (1) Latched SPDT
Contact rating:	250 VAC, 10A, 1/4 hp.
Contact latch:	LC10: N/A LC11: Select On/Off
Contact delay:	0 to 60 seconds
LED indication:	Sensor, relay & power status
Electronics temp.:	F: -40° to 158° C: -40° to 70°
Enclosure rating:	NEMA 4X (IP65)
Enclosure material:	10_1: PP (U.L. 94 VO) 10_2: PP (U.L. 94 VO) and Polycarbonate
Enclosure mount.:	100_: 3/4" NPT 105_: 3/4" Rp
Enclosure rotation:	300° swivel base
Conduit entrance:	Single, 1/2" NPT
Certificate number:	LR 79326-3
CE compliance:	EN 61326 EMC EN 61010-1 Safety

**Dimension:
LC1_-10_1**

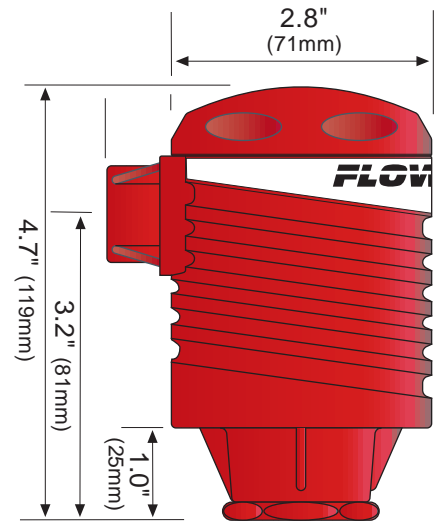

**Dimension:
LC10-10_2**

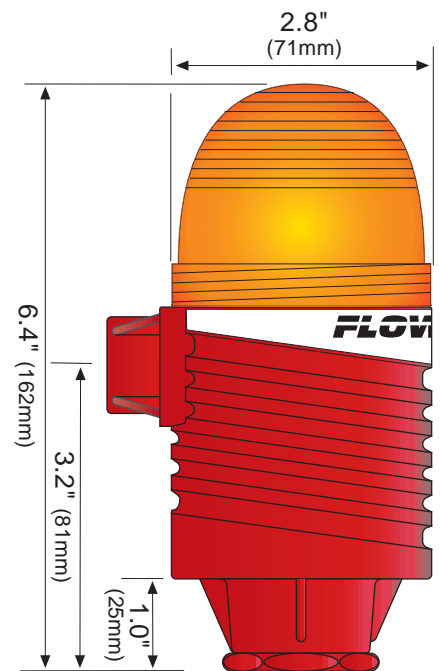

Part Number Information:

Part #	Thread	Description
LC10-1001 ⁽¹⁾⁽²⁾	3/4" NPT	High or Low Relay Controller
LC10-1051 ⁽¹⁾⁽²⁾	3/4" BSP	High or Low Relay Controller
LC10-1002 ⁽²⁾	3/4" NPT	High or Low Relay Controller with Strobe Alert
LC10-1052 ⁽²⁾	3/4" BSP	High or Low Relay Controller with Strobe Alert
LC11-1001 ⁽¹⁾⁽²⁾	3/4" NPT	Automatic Fill or Empty Relay Controller
LC11-1051 ⁽¹⁾⁽²⁾	3/4" BSP	Automatic Fill or Empty Relay Controller

⁽¹⁾ Adding -CE to end of part number signify CE configuration of controller

⁽²⁾ Adding -E to end of part number signify 240 VAC configuration of controller

Internal Controller Logic

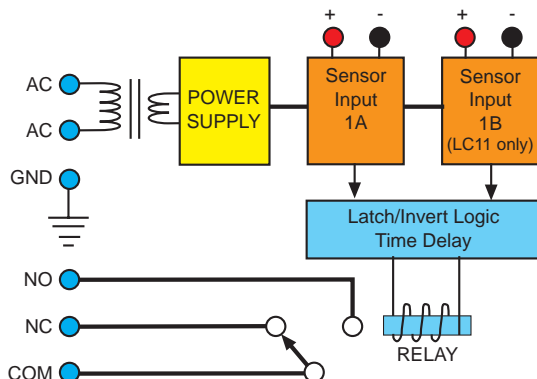

LC11-1001 Faceplate

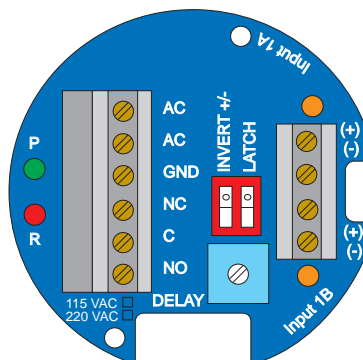

LC10-1001 Faceplate

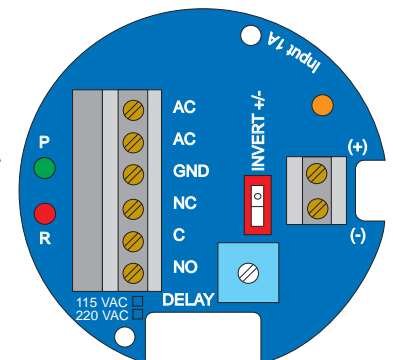

SAFETY PRECAUTIONS

Step Two

About This Manual:

PLEASE READ THE ENTIRE MANUAL PRIOR TO INSTALLING OR USING THIS PRODUCT. This manual includes information on three different models of Compact Relay Controllers from Flowline: LC10-10_1, LC10-10_2 and LC11-10_1. The LC10 is a single-input controller with an optional Strobe Alert™ on the -10_2 model, and the LC11 is a dual-input controller. Many aspects of installation and use are similar between the three models.

User's Responsibility for Safety:

FLOWLINE manufactures several models of controller, with different mounting and switching configurations. It is the user's responsibility to select a controller model that is appropriate for the application, install it properly, perform tests of the installed system, and maintain all components.

Electrical Shock Hazard:

It is possible to contact components on the controller that carry high voltage, causing serious injury or death. All power to the controller and the relay circuit(s) it controls should be turned OFF prior to working on the controller. If it is necessary to make adjustments during powered operation, use extreme caution and use only insulated tools. Making adjustments to powered controllers is not recommended. Wiring should be performed by qualified personnel in accordance with all applicable national, state and local electrical codes.

Flammable or Explosive Applications:

Sensor mount controllers should not be used with explosive or flammable liquids, which require an intrinsically safe rating such as the Flowline LC90 series. If you are unsure of the suitability of a controller for your installation, consult your Flowline representative for further information.

Install In a Dry Location:

The LC10 and LC11 series controller housing is liquid-resistant and made of Polypropylene (PP). When installed properly, the controller is not designed to be immersed. It should be mounted in such a way that it does not normally come into contact with fluid. Refer to an industry reference to ensure that compounds that may splash onto the controller housing will not damage it. Such damage is not covered by the warranty.

Relay Contact Rating:

The relay is rated for a 10 amp resistive load. Many loads (such as a motor during start-up or incandescent lights) are reactive and may have an inrush current characteristic that may be 10 to 20 times their steady-state load rating. The use of a contact protection circuit may be necessary for your installation if the 10 amp rating does not provide an ample margin for such inrush currents.

INTRODUCTION

Step Three

Make a Fail-Safe System:

Design a fail-safe system that accommodates the possibility of relay or power failure. If power is cut off to the controller, it will de-energize the relay. Make sure that the de-energized state of the relay is the safe state in your process. For example, if controller power is lost, a pump filling a tank will turn off if it is connected to the Normally Open side of the relay.

While the internal relay is reliable, over the course of time relay failure is possible in two modes: under a heavy load the contacts may be "welded" or stuck into the energized position, or corrosion may build up on a contact so that it will not complete the circuit when it should. In critical applications, redundant backup systems and alarms must be used in addition to the primary system. Such backup systems should use different sensor technologies where possible.

While this manual offers some examples and suggestions to help explain the operation of FLOWLINE products, such examples are for information only and are not intended as a complete guide to installing any specific system.

Sensor-mount controllers:

The LC10/LC11 is a cost-effective, modular liquid level controller whose body incorporates a female 3/4" NPT (3/4" BSP) fitting, allowing it to be mounted directly onto any Flowline sensor or Switch Pak™ or any 3/4" connection. Simply provide its required AC power and a controlled device such as a valve, pump, or alarm that can be switched by the controller's relay in response to the sensor input.

Sensor-mount controllers are particularly appropriate for simple processes such as high or low alarms. They can also be a useful part of more complicated systems, providing a fail-safe backup in case a centralized system fails.

Features of the LC10 Single Input Controller:

The LC10 Controller is designed to receive a signal from a single liquid sensor. It turns its internal relay On or Off (as set by the invert switch) in response to the presence of liquid, and changes the relay status back again when the sensor is dry. The LC10 may be used with almost any kind of sensor signal: current sensing, contact closure, or FET switch. The relay is a single pole, double throw type; the controlled device can be connected to either the normally open or normally closed side of the relay. A time delay from 0 to 60 seconds can be set before the relay responds to the sensor input.

Typical applications for the LC10 are high level or low level switch/alarm operations (opening a drain valve whenever liquid level rises to a sensor point) and leak detection (sounding an alarm when a leak is detected, etc.).

Features of the LC11 Single Input Controller:

The LC11 Controller is designed to receive signals from two liquid sensors. It turns its internal relay On or Off (as set by the invert switch) in response to the presence of liquid on both sensors, and changes the relay status back again when both sensors are dry. The LC11 may be used with almost any kind of sensor signal: current sensing, contact closure, or FET switch. The relay is a single pole, double throw type; the controlled device can be connected to either the normally open or normally closed side of the relay. A time delay from 0 to 60 seconds can be set before the relay responds to the sensor input.

Typical applications for the LC11 are automatic filling (starting fill pump at a low level and stopping pump at a high level) or automatic emptying operations (opening a drain valve at a high level and closing valve at low level).

GUIDE TO CONTROLS

Step Four

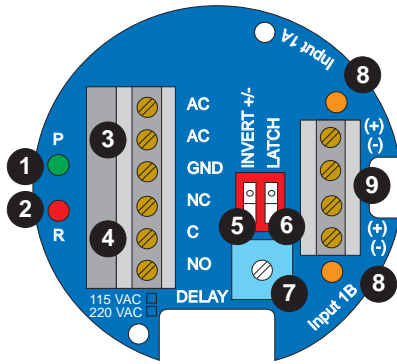

- 1. Power indicator:** This green LED lights when AC power is ON.
- 2. Relay indicator:** This red LED will light whenever the controller energizes the relay, in response to the proper condition at the sensor input(s) and after the time delay.
- 3. AC Power terminals:** Connection of 120 VAC power to the controller. The setting may be changed to 240 VAC if desired. This requires changing internal jumpers; this is covered in the Installation section of the manual. Polarity (neutral and hot) does not matter.
- 4. Relay terminals (NC, C, NO):** Connect the device you wish to control (pump, alarm etc.) to these terminals: supply to the COM terminal, and the device to the NO or NC terminal as required. The switched device should be a noninductive load of not more than 10 amps; for reactive loads the current must be derated or protection circuits used. When the red LED is ON and the relay is in the energized state, the NO terminal will be closed and the NC terminal will be open.
- 5. Invert switch:** This DIP switch reverses the logic of the relay control in response to the sensor(s): conditions that used to energize the relay will make it turn off and vice versa.
- 6. Latch switch (LC11 only):** This DIP switch determines how the relay will be energized in response to the two sensor inputs. When LATCH is OFF, the relay responds to sensor Input 1A only; when LATCH is ON, the relay will energize or de-energize only when both sensors (1A and 1B) are in the same condition (wet or dry). The relay will remain latched until both sensors change states.
- 7. Time Delay:** After the input(s) change(s) state, this control sets a delay from 0.15 to 60 seconds before the relay will respond.
- 8. Input 1A and 1B indicator:** These amber LEDs will light immediately whenever the appropriate sensor attached to the terminals detects liquid, and will turn off when it is dry.
- 9. Input terminals:** Connect the wiring from the sensors to these terminals: A to the upper pair, B (LC11 only) to the lower pair. Note the polarity: (+) is a 13.5 VDC, 27 mA power supply (to be connected to the red wire of a Flowline sensor), and (-) is the return path from the sensor (to be connected to the black wire of a Flowline sensor). If polarity is reversed, the sensors will not work.

INSTALLATION

Step Five

3/4" NPT Mounting Thread:

Installation of the compact relay controller takes advantage of the 3/4" NPT thread located on its base. This makes the controller fully compatible with any of Flowline's level switches or Smart Trak™ or Switch Pak™ mounting systems.

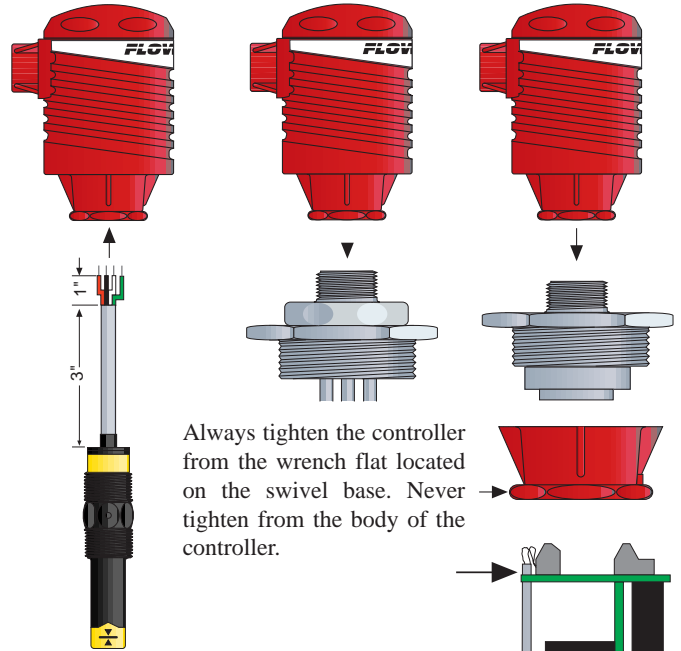

Switch Cable:

When installing a Flowline level switch, adjust the cable away from the printed circuit boards in the controller body. Avoid breaking the seal between the top of the level switch and the plastic coated cable.

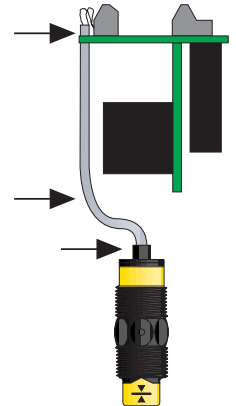

Connecting switches to input terminals:

Please note a difference between FLOWLINE powered level switches and reed switches. All powered level switches (models LO10, LP10, LP15, LP50, LU10, LZ12) will be wired with the Red wire to the (+) terminal and the Black wire to the (-) terminal. FLOWLINE reed switches (models LV10, LV20, LV30, LH20 and LH30) will have a particular wiring based upon part number. See the illustration below to indicate wiring for your switch. *Note: the Shield wire will be used only for long cable runs or where excessive electrical noise is present.*

FLOWLINE Powered Switch

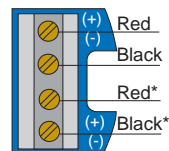

Models
LZ10, LU10,
LP50, LP15,
LP10, LO10,
LV10-2_1

FLOWLINE Reed Switch

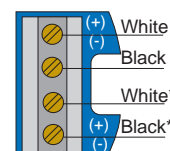

Models
LV10-3_1
LH10

* Terminals available on LC11 Only

* Terminals available on LC11 Only

INSTALLATION

Step Six

VAC Power Input Wiring:

Observe the labeling on the LC10/LC11. *Note: Polarity does not matter with the AC input terminal.*

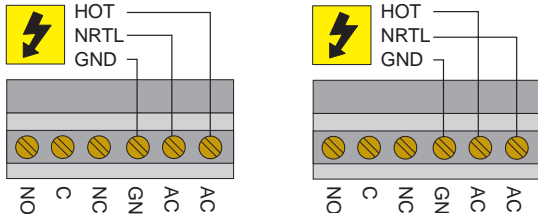

Relay Input Wiring

The relay is a single pole, double throw type rated at 250 Volts AC, 10 Amps, 1/4 Hp. The two terminal NO and NC (normally open and normally closed) will be used in different applications. Remember that the "normal" state is when the relay coil is de-energized and the Red relay LED is Off / de-energized.

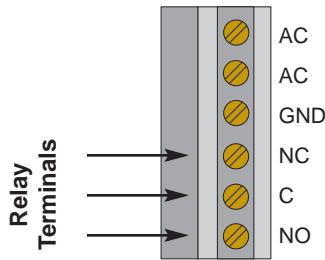

Strobe Alert Output

With the Strobe Alert wired NC, it can be used as a high or low level alarm, depending on the setting for the invert switch. Strobe can also be wired NO.

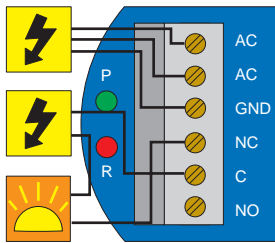

Changing from 120 to 240 VAC

1. Remove the two screws from the top of the printed circuit board (PCB) and gently slide the PCB from the housing. Use caution when removing the PCB.
2. Located jumpers JWA, JWB and JWC on the PCB.
3. To change to 240 VAC, remove jumpers from JWB and JWC and place a single jumper across JWA. To change to 120 VAC, remove jumper JWA and place jumpers across JWB and JWC.
4. Gently return PCB into housing and replace the two screws.

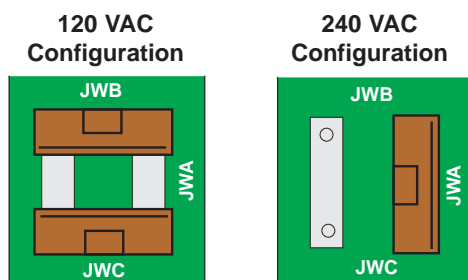

APPLICATION EXAMPLES

Step Seven

Low Level Alarm

The goal is to make sure that the liquid level does not fall below a certain point. If it does, an alarm is supposed to sound, alerting the operator of a low level condition.

If power is accidentally cut to the controller, the sensor's ability to notify the operator of a low level condition could be lost. The system must alert the operator not only to low liquid level, but to controller power loss.

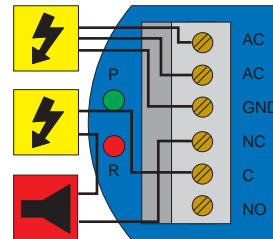

To do this, connect the hot lead of the alarm to the NC side of the relay terminal of the controller. If power is lost, the relay will be de-energized, and the alarm will sound (if there is still power to the alarm circuit itself). The alarm circuit should have a non-interruptible power supply or some other indicator or backup alarm to warn of a power failure in the alarm circuit.

In this application, the normal status if the sensor at the bottom if the tank will be wet, and the relay will be energized holding the alarm circuit open. Both the relay LED and the Input LED will be on simultaneously, so for this application, *Invert should be set to the Off position.*

High Level Alarm

In the same manor, this system can be used to sound an alarm when fluid reaches a high level, with just a change in the location of the sensor and the setting of the Invert switch.

The alarm is still connected to the NC side of the relay to allow for a power failure alarm.

The sensor is normally dry. In this condition, we want the relay to be energized so the alarm does not sound: i.e., the Red relay LED should be on whenever the Input LED is Amber. *So we turn Invert On.* If the fluid level rises to the high sensor point, the sensor goes on, the relay de-energizes, and the alarm sounds.

LED Indication:

Use LED's located above the input terminals to indicate whether the switch is in a wet or dry state. With powered switches, Green indicates dry and Amber indicates wet. With reed switches, Amber indicates wet and no LED indicates dry. Note: reed switches may be wired in reverse so that wet indicates dry and Amber indicates dry.

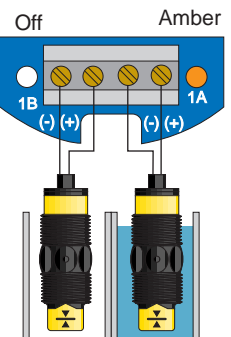

APPLICATION EXAMPLES

Step Eight

Automatic Fill:

This system consists of a tank with a high level sensor, a low level sensor, and a pump that is controlled by the controller. Part of a proper fail-safe design for this particular system is that if power is lost to the controller for any reason, the pump filling the tank must be turned off. Therefore, we connect the pump to the NO side of the relay. When the relay is energized, the pump will turn on and fill the tank. The relay indicator will correspond directly to the On/Off status of the pump.

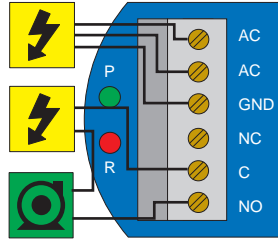

NOTE: If the pump motor load exceeds the rating of the controller's relay, a stepper relay of higher capacity must be used as part of the system design.

Determining the settings of LATCH and INVERT

This is the way the system must operate:

- When both the high and low sensors are dry, the pump should turn on, starting to fill the tank.
- When the low sensor gets wet, the pump should stay on.
- When the high sensor gets wet, the pump should turn off.

Latch: In any two-sensor control system, LATCH must be ON.

Invert: Referring to the logic chart in Step Nine, we look for the setting that will de-energize the relay (start the pump) when both inputs are wet (Amber LEDs). *In this system, Invert should be ON.*

Determining A or B input connections: When LATCH is ON, there is no effective difference between Input A and B, since both sensors must have the same signal in order for status to change. When wiring any two-input relay section, the only consideration for hooking a particular sensor to A or B is if LATCH will be OFF.

Automatic Empty:

Note that a similar system logic can be used for an automatic empty operation simply by controlling a pump that pumps fluid out of the tank instead of into it. However, note the importance of fail-safe design. If the tank is being passively filled, and a pump must be used to actively empty it, a power failure to either the controller or the pump circuits will cause overflow.

Alternatively, an electrically-controlled drain valve could be used. In this case, the valve should be a type that will automatically open if power is lost; in other words, power must be used to hold it closed. The valve would be connected to the NO side of the relay—if power is lost to the controller, the relay de-energizes, the valve loses the power that was holding it shut, and fluid will drain from the tank into some other safe containment until power is restored. In this system, whenever the red relay LED of the controller is ON, the drain is closed, allowing fluid to rise.

In this case, Invert should be On: when both sensors are wet, the relay de-energizes, the switch to the valve opens, and the tank will drain.

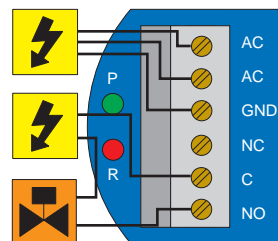

TROUBLESHOOTING

Step Nine

Controller Logic

For all controllers, please use the following guide to understand the operation of the FLOWLINE LC11 controllers.

- 1. Power LED:** Make sure the Green power LED is On when power is supplied to the controller.
- 2. Input LED(s):** The input LED(s) on the controller will be Amber when the switch(es) is/are wet and Off when the switch(es) is/are dry. *Note: see Step 5 regarding reed switches.* If the LED's are not switching the input LED, test the level switch.
- 3. LC10 only:** When the input LED turn Off and On, the relay LED will also switch. With invert Off, the relay LED will be On when the input LED is On and Off when the input LED is Off. With invert On, the relay LED will be Off when the input LED is On and On when the input LED is Off.
- 4. LC11 only:** When both inputs are wet (Amber LED's On), the relay will be energized (Red LED On). After that, if one switch becomes dry, the relay will remain energized. Only when both switches are dry (both amber LED's Off) will the controller de-energize the relay. The relay will not energize again until both switches are wet. See the Relay Latch Logic Chart below for further explanation.

Relay Latch Logic Table (LC11 Only):

The relay can either be an independent relay (high or low level alarm) or can be a latching relay (automatic fill or empty) with latch ON. With Latch Off, the relay will only respond to the INPUT 1A setting. INPUT 1B will be ignored.

Invert OFF		Latch Off	Invert ON		Latch Off
Input1A	Input1B	Relay	Input1A	Input1B	Relay
ON	No Effect	ON	ON	No Effect	OFF
OFF	No Effect	OFF	OFF	No Effect	ON

With Latch ON, the relay will actuate when INPUT 1A and INPUT 1B are in the same condition. The relay will not change its condition until both inputs reverse their state.

Invert OFF		Latch Off	Invert OFF		Latch Off
Input1A	Input1B	Relay	Input1A	Input1B	Relay
ON	ON	ON	ON	ON	OFF
OFF	ON	No Change	OFF	ON	No Change
ON	OFF	No Change	ON	OFF	No Change
OFF	OFF	OFF	OFF	OFF	ON

Caution: Some sensors (particularly buoyancy sensors) may have their own inverting capability (wired NO or NC). This will change the logic of the invert switch. Check your system design.