

## Warranty, Service & Repair

To register your product with the manufacturer, go to the Flowline website for on-line registration. The website address is as follows:

**[www.flowline.com](http://www.flowline.com)**

On-line Warranty Registration can be found under Contact Us in the Navigation Bar along the side of the home page.

If for some reason your product must be returned for factory service, contact Flowline Inc. at (562)598-3015 to receive a Material Return Authorization number (MRA), providing the following information:

1. Part Number, Serial Number
2. Name and telephone number of someone who can answer technical questions related to the product and its application.
3. Return Shipping Address
4. Brief Description of the Symptom
5. Brief Description of the Application

Once you have received a Material Return Authorization number, ship the product prepaid in its original packing to:

Flowline Factory Service  
MRA \_\_\_\_\_  
10500 Humbolt Street  
Los Alamitos, CA 90720

To avoid delays in processing your repair, write the MRA on the shipping label. Please include the information about the malfunction with your product. This information enables our service technicians to process your repair order as quickly as possible.

# FLOWLINE®

## Switch Pro™

### w/ Compact Junction Box

### A\_1\_ Series Owner's Manual



Version 0.1A

© 2005 FLOWLINE Inc.

All rights reserved.

Manual # FT900004

05/05

## WARRANTY

Flowline warrants to the original purchaser of its products that such products will be free from defects in material and workmanship under normal use and service for a period which is equal to the shorter of one year from the date of purchase of such products or two years from the date of manufacture of such products.

This warranty covers only those components of the products which are non-moving and not subject to normal wear. Moreover, products which are modified or altered, and electrical cables which are cut to length during installation are not covered by this warranty.

Flowline's obligation under this warranty is solely and exclusively limited to the repair or replacement, at Flowline's option, of the products (or components thereof) which Flowline's examination proves to its satisfaction to be defective. FLOWLINE SHALL HAVE NO OBLIGATION FOR CONSEQUENTIAL DAMAGES TO PERSONAL OR REAL PROPERTY, OR FOR INJURY TO ANY PERSON.

This warranty does not apply to products which have been subject to electrical or chemical damage due to improper use, accident, negligence, abuse or misuse. Abuse shall be assumed when indicated by electrical damage to relays, reed switches or other components. The warranty does not apply to products which are damaged during shipment back to Flowline's factory or designated service center or are returned without the original casing on the products. Moreover, this warranty becomes immediately null and void if anyone other than service personnel authorized by Flowline attempts to repair the defective products.

Products which are thought to be defective must be shipped prepaid and insured to Flowline's factory or a designated service center (the identity and address of which will be provided upon request) within 30 days of the discovery of the defect. Such defective products must be accompanied by proof of the date of purchase.

Flowline further reserves the right to unilaterally waive this warranty and to dispose of any product returned to Flowline where:

- a. There is evidence of a potentially hazardous material present with product.
- b. The product has remained unclaimed at Flowline for longer than 30 days after dutifully requesting disposition of the product.

THERE ARE NO WARRANTIES WHICH EXTEND BEYOND THE DESCRIPTION ON THE FACE OF THIS WARRANTY. This warranty and the obligations and liabilities of Flowline under it are exclusive and instead of, and the original purchaser hereby waives, all other remedies, warranties, guarantees or liabilities, express or implied. EXCLUDED FROM THIS WARRANTY IS THE IMPLIED WARRANTY OF FITNESS OF THE PRODUCTS FOR A PARTICULAR PURPOSE OR USE AND THE IMPLIED WARRANTY OF MERCHANTABILITY OF THE PRODUCTS.

This warranty may not be extended, altered or varied except by a written instrument signed by a duly-authorized officer of Flowline, Inc.

# SPECIFICATIONS

## Step One

### Specifications:

Set point range:	AT1_: .04 to 3 fps (.012 to .91 mps)
	AG1_: 1 to 90 fps (.3 to 27 mps)
Factory set point:	AT1_: .2 fps (.06 mps)
	AG1_: 10 fps (3 mps)
Repeatability:	±.5% of set point @ fixed temp.
Response time:	1 to 10 seconds
Set point adjust.:	Potentiometer
Viscosity range:	AT1_: 1 to 200 centipoise
	AG1_: N/A
Supply voltage:	12 to 36 VDC
Consumption:	70 mA maximum
Contact type:	(1) SPST relay
Contact rating:	120 VAC/VDC @ 1A
Contact output:	Selectable NO/NC
LED indication:	Flow status
Process temp.:	F: 32° to 160° C: 0° to 60°
Electronics temp.:	F: -40° to 160° C: -40° to 60°
Pressure:	150 psi (10 bar) @ 25 °C., derated @ 1.667 psi (.113 bar) per °C. above 25 °C.
Wetted material:	161_: PP-Ryton® 163_: PVDF Kynar®
Process mount:	3/4" NPT (3/4" G)
Mount. gasket:	Viton (G version only)
Enclosure rating:	NEMA 4X (IP65)
Encl. material:	PP, UL94VO
Conduit entrance:	Single, 1/2" NPT
Termination:	6-poles
Classification:	General purpose
CE compliance:	EN 50082-2 immunity EN 55011 emission EN 61010-1 safety

### Dimensions (w/ ultrasonic sensor):

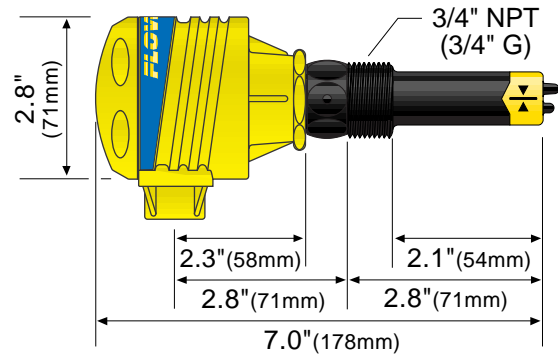

### Dimensions (w/ horizontal buoyancy sensor):

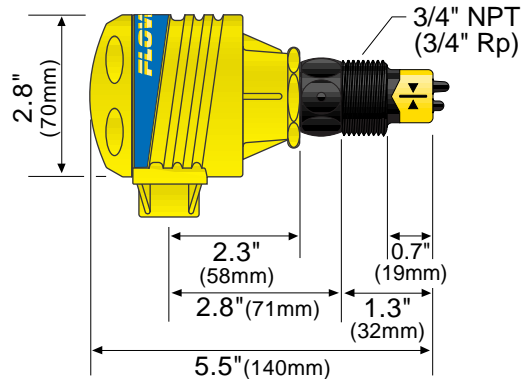

**Set Points:** The AT1\_-\_63\_ series liquid flow switch set point is factory calibrated to 0.2 fps and the AG1\_-\_36\_ series gas flow switch is set to 10 fps. To convert feet/sec to GPM, please refer to the chart below.

### Sensor Technologies:

#### Thermal Dispersion - Liquid (FT10 series)



Best applied in clean water or water-like chemical media that is non-coating or crystallizing

#### Thermal Dispersion - Gas (GT10 series)



Best applied in clean air or aggressive media that is non-coating and particular free

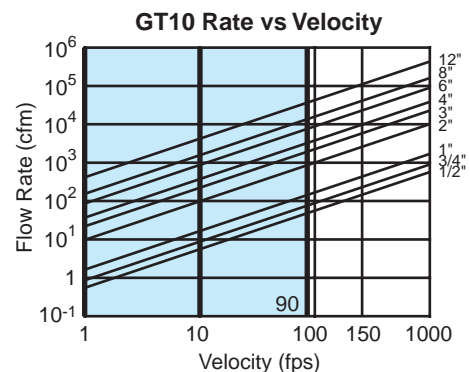
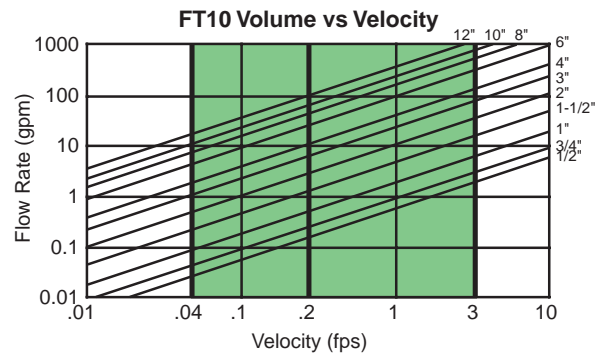

## COMPONENTS

### Step Two

#### Standard Configuration:

AT18-63\_ or AG18-63\_

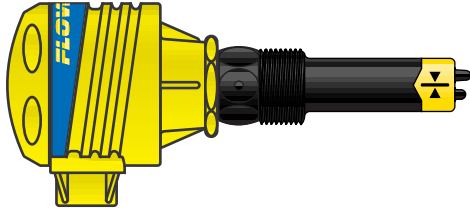

#### Long Switch

##### AT18-1630

1 x FT10-1405  
1 x LC06-1001

##### AT18-1630

1 x FT10-5405  
1 x LC06-1001

##### AT18-1634

1 x FT10-1425  
1 x LC06-1051

##### AT18-1634

1 x FT10-5425  
1 x LC06-1051

AT17-63\_ or AG17-63\_

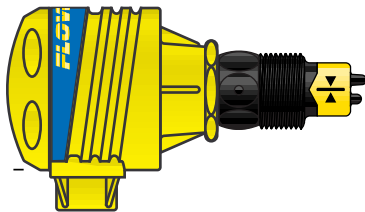

#### Short Switch

##### AT17-1630

1 x FT10-1305  
1 x LC06-1001

##### AT17-1630

1 x FT10-5305  
1 x LC06-1001

##### AT17-1634

1 x FT10-1325  
1 x LC06-1051

##### AT17-1634

1 x FT10-5325  
1 x LC06-1051

#### Component List:

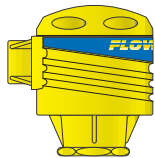

**Compact Relay Controller**  
P/N: LC06-1001 or LC06-1051



**Switch-Tek Level Switch**  
P/N: LU10-1405, LU10-1425,  
LU10-2405, LU10-2425

## CALIBRATION

### Step Three

**Set Points:** If the preset factory calibration is not adequate for your application, follow the calibration steps listed below. *Note: the switch's internal LED will be on when the switch detects no-flow and will off when the switch detects flow.*

1. Install the fitting and flow switch as described in the Installation section of this manual. Turn the flow switch and controller power on and adjust the flow rate to the application setting. If the medium to be sensed is likely to be subject to high temperature variations, the flow switch should be set at the highest normal temperature likely to be encountered.

2. Locate the potentiometer knob at the top of the flow switch. The red LED is visible through the potentiometer. (If the LED is on, slowly adjust the potentiometer counterclockwise, with a small flat head screwdriver until the LED turns off.) The adjustment is a single turn 270° potentiometer. The initial response time of the flow switch after adjustment is 1 to 10 seconds. Adjust the potentiometer in slow increments and wait for the response.



If the LED is off, slowly adjust the potentiometer clockwise until the light turns on. Then turn the potentiometer counterclockwise to bring the LED off at a reliable setting. Remember, adjust the potentiometer in slow increments and wait for the response.

3. Verify that the new calibration is correct by lowering the system flow rate below the set point and check to see that the red LED turns on. Then increase the flow rate above the set point and verify that the red LED turns off accordingly.

#### Liquid Switch AT1-63\_Series

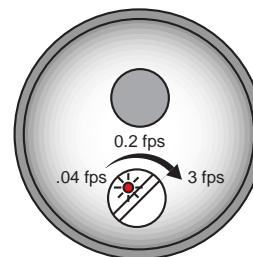

#### Gas Switch AG1-63\_Series

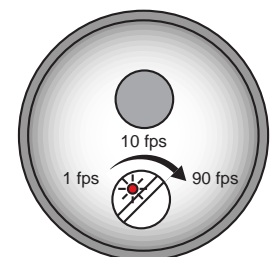

## SAFETY PRECAUTIONS

### Step Four

**⚠ About this Manual:** PLEASE READ THE ENTIRE MANUAL PRIOR TO INSTALLING OR USING THIS PRODUCT. This manual includes information on the Switch Pro™ with Compact Junction Box (Flow): AT1-\_63\_ and AG1-\_63\_. The units are identical except for the material of construction and the sensors technology.

**⚠ User's Responsibility for Safety:** Flowline manufactures a wide range of liquid sensors, controllers, and mounting systems. It is the user's responsibility to select components that are appropriate for the application, install them properly, perform tests of the installed system, and maintain all components. The failure to do so could result in property damage or serious injury.

**⚠ Proper Installation and Handling:** Use a proper sealant with all installations. Never overtighten the components. Always check for leaks prior to system start-up.

**⚠ Material Compatibility:**  
**Polypropylene (PP, a polyolefin):** Sensor, Junction Box.

**Ryton:** Sensor (A\_1\_-363\_ only).

**Polyvinylidene Fluoride (PVDF):** Sensor and Switch Pro™ fitting.

Make sure that the application liquids are compatible with the materials that will be wetted. To determine the chemical compatibility between the components and its application liquids, refer to the Compass Corrosion Guide, available from Compass Publications (phone 858-589-9636).

**⚠ Temperature and Pressure:** Switch Pro™ is designed for use in application temperatures up to 50° C (140° F). The assembly is also designed for pressurized applications up to 150 psi (10 bar).

**⚠ Wiring and Electrical:** Electrical wiring of any liquid or gas control system should be performed in accordance with all applicable national, state, and local codes. Take care not to cut or break the outer insulation jacket of wiring that may be immersed while routing cables in the Switch Pro™ system. Such breaks of the liquid seal of the sensor system may lead to component failure.

**⚠ Flammable, Explosive and Hazardous Applications:** The AT17-\_63\_, AT18-\_63\_, AG17-\_63\_ and AG18-\_63\_ Switch Pro™ should not be used within classified hazardous environments.

**⚠ Make a Fail-Safe System:** Design a fail-safe system that accommodates the possibility of system or power failure. In critical applications, Flowline recommends the use of redundant back-up systems and alarms in addition to the primary system.

## ASSEMBLY OF SWITCH PAK™

### Step Five

**About Switch Pro™:** Flowline's Switch Pro™ with Compact Junction Box Assembly is a single-point mounting system for installing one flow sensor within a pipe or fume. The compact junction box features termination for the various wires from each level switch as well as a 1/2" conduit connection. Switch Pro™ mounts horizontally through a standard 3/4" NPT fitting.

**Flow Switches:** Switch Pro™ includes a single flow switch used to identify its own unique flow / no-flow condition. The technologies used to indicate flow is Thermal Dispersion. Both the liquid and gas configurations feature similar wiring/power configuration (12 to 36 VDC power for operation, see below). The switch is terminated in the Compact Junction Box. The Compact Junction Box provides a 1/2" Conduit connection and 6 poles for wire termination.



**Compact Junction Box (inside shown)**

### Liquid (FT10-\_4\_5 or FT10-\_4\_5) Wire Configuration:

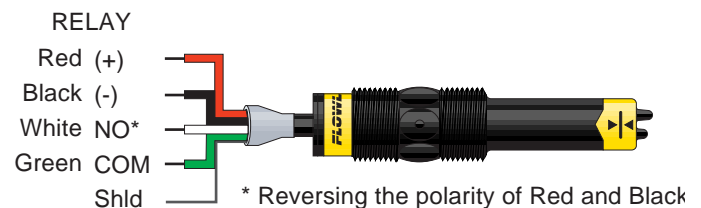

### Gas (GT10-\_4\_5 or GT10-\_4\_5) Wire Configuration:

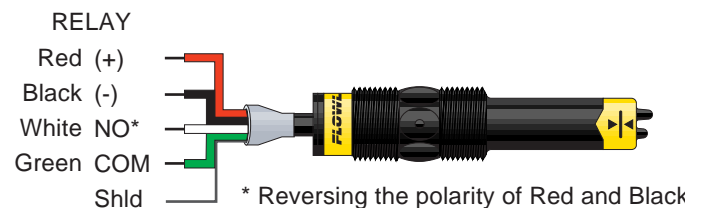

# INSTALLATION

## Step Six

The AT1\_ series flow switch when installed must always be in contact with the liquid being measured. The AG1\_ series flow switch when installed must never be submersed in liquid. Both flow switches feature a 3/4" NPT threads which will allow it to be used with various types of fittings. Be sure to check the insertion depth of the flow switch in the fitting after it is installed. See the diagram below for the recommended insertion depth.

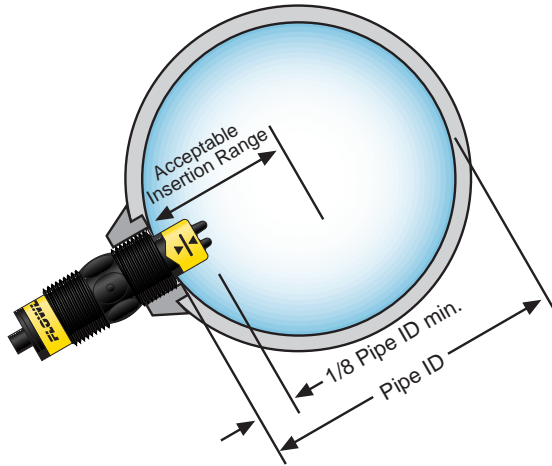

When using any type of fitting, the orientation as well as the insertion depth of the flow switch in the pipe is critical. See the diagram below for the recommended orientation depth.

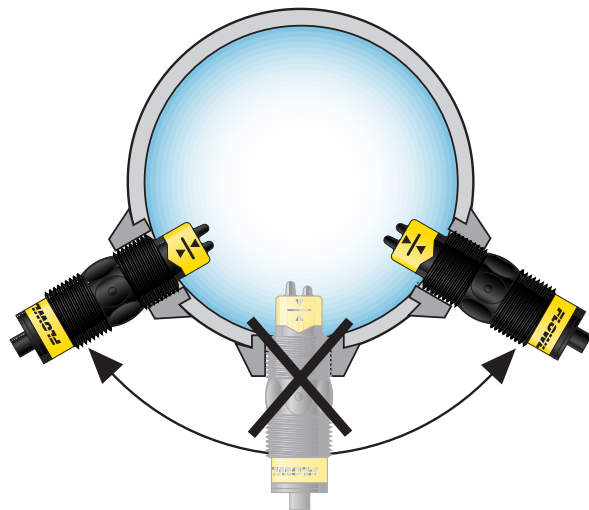

### ⚠ WARNING ⚠

The flow switch tips have a thin plastic wall which may be damaged if dropped or installed improperly.

The AT17 and AT18 flow switches are designed for use in liquid. For best results, avoid installing the AT1\_ where bubbles are present or where the tips of the switch may be out of the liquid.

The AG17 and aG18 flow switches are designed for use in gas applications. For best results, avoid installing the AG1\_ where it may be submersed in liquid.

Note: Always install the Viton gasket with all versions of the AT1\_-\_634 and AG1\_-\_634. The G threaded version will not seal unless the gasket is properly installed.

# WIRING

## Step Seven

**Supply Voltage:** The supply voltage to the Switch-Pro™ flow switch should never exceed a maximum of 36 VDC. Use controllers or power supplies, with a minimum output of 12 VDC or a maximum output of 36 VDC.

**Required Cable Length:** Determine the length of cable required between the Switch-Pro™ flow switch and its point of termination. Allow enough slack to ensure the easy installation, removal and/or maintenance of the sensor. The cable length may be extended up to a maximum of 1000 feet, using a well-insulated, 14 to 20 gauge shielded four conductor cable.

**Wire Stripping:** Using a 10 gauge wire stripper, carefully remove the outer layer of insulation from the last 1-1/4" of the sensor's cable. Unwrap and discard the exposed foil shield from around the signal wires, leaving the drain wire attached if desired. With a 20 gauge wire stripper, remove the last 1/4" of the colored insulation from the signal wires.

**Signal Output (Relay switching):** Allows the sensor to switch a small load on or off directly, using an internal 1A relay [120 VAC/VDC or (CE: 60 VAC/VDC)]. The NO/NC status is set by the polarity of the voltage feeding the red and black wires. The green wire is the common for the relay and the white wire is the NO or NC, depending on the polarity of red and black.

### Normally Open Wiring:

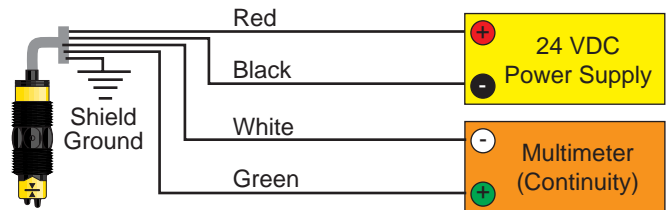

### Wiring to a Flowline Controller: LC30 Series Controller

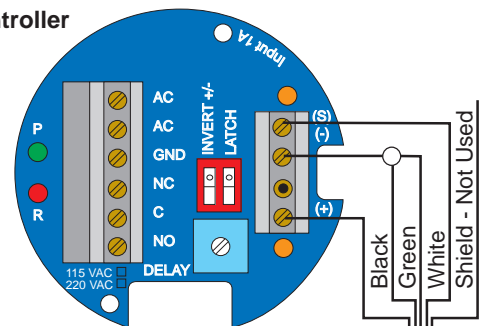

### LC80 Series Controller

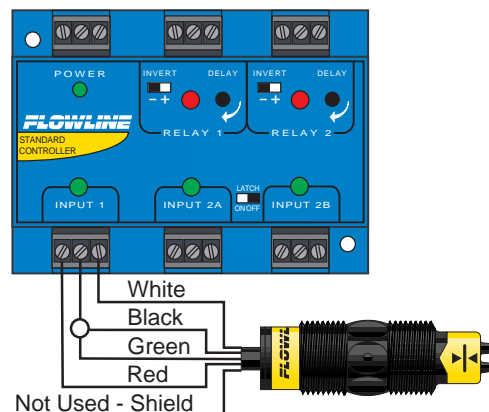

# WIRING

## Step Eight

### Wiring the Relay Output:

The Switch-Pro™ relay output can be wired as a dry contact to a VDC or VAC power source. Switch-Pro™ does require 12 - 36 VDC power to operate the sensor and switch the relay. All illustrations below identify a Dry switch state as the normal position of the relay.

### Switching a Normally Open DC Load:

The Red wire connects to Positive (+) of the power supply and the Black wire connects to Negative (-). The LOAD can be attached to either the Green or White wires. Complete the circuit by either connecting the Green to (+) VDC power or White to (-) VDC power (see illustration below).

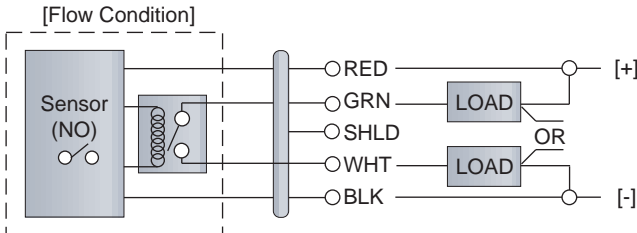

### Switching a Normally Closed DC Load:

The Black wire connects to Positive (+) of the power supply and the Red wire connects to Negative (-). The LOAD can be attached to either the Green or White wires. Complete the circuit by either connecting the Green to (+) VDC power or White to (-) VDC power (see illustration below).

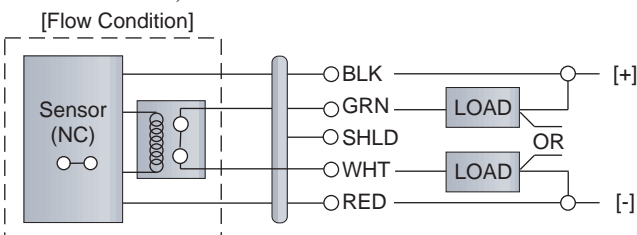

### Switching a Normally Open AC Load:

The Red wire connects to Positive (+) of the DC power supply and the Black wire connects to Negative (-). The LOAD can be attached to the Green wire and the Hot of the VAC power. Connect the White to the Neutral of the VAC power (see illustration below).

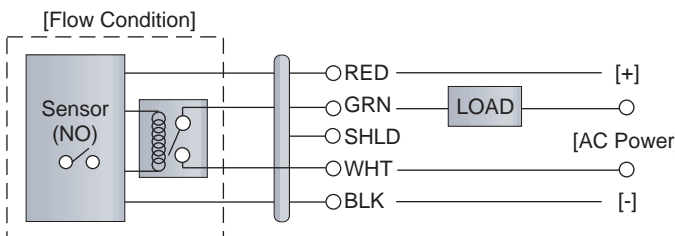

### Switching a Normally Closed AC Load:

The Black wire connects to Positive (+) of the DC power supply and the Red wire connects to Negative (-). The LOAD can be attached to the Green wire and the Hot of the VAC power. Connect the White to the Neutral of the VAC power (see illustration below).

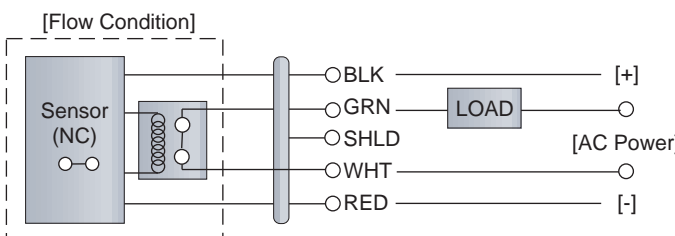

# MAINTENANCE

## Step Nine

**General:** The Switch-Pro™ flow switch requires no periodic maintenance except to clean off any deposits or scaling from the sensor tip as necessary. It is the responsibility of the user to determine the appropriate maintenance schedule, based on the specific characteristics of the application liquids.

### Cleaning Procedure:

- 1. Power:** Make Sure that all power to the sensor, controller and/or power supply is completely disconnected.
- 2. Sensor Removal:** *Make sure that the flow is off and the pressure is down prior to removing the Switch-Pro™.* Carefully, remove the sensor from the installation. Replace the sensor with a 3/4" NPT plug to insure that liquid does not leak out during this procedure. **Do not re-install the Switch-Pro™ if the threads are damaged.**
- 3. Cleaning the Sensor:** Use a soft bristle brush and mild detergent, carefully wash the Switch-Pro™ flow switch. Do not use harsh abrasives such as steel wool or sandpaper, which might damage the surface sensor. Do not use incompatible solvents which may damage the sensor's PP/Ryton or PVDF plastic body.
- 4. Sensor Installation:** Follow the appropriate steps of installation as outlined in the installation section of this manual.

### Testing the Flow Switch:

Used to verify if the sensor is indicating a no-flow or flow condition. This test uses all four-wires (Red, Black, White and Green). With Red to Positive and Black to Negative, the Contacts (White and Green) will be Open in a Flow Condition and Closed in a No-Flow Condition. Also, the Red LED in the switch will be OFF for a Flow Condition and ON for a No-Flow Condition.

